



an EnPro Industries company

QRNG[®] Series Model QRNG 325

Parts Manual
Record of Change 105

This manual contains important safety information and must be made available to all personnel who operate and/or maintain this product. Carefully read this manual before attempting to operate or perform maintenance on this compressor.

Fill Out & Return Warranty Registration Card Located Inside

Manual No. 50160-105

February 2008 Edition

INTRODUCTION

This manual provides information for the QRNG Series, Model QRNG325 natural gas compressor per Record of Change 105.

The Model QRNG325 natural gas compressor is an aircooled, two stage, two cylinder, pressure lubricated compressor, capable of handling inlet pressures of -7.5 PSI (15 in. mercury) up to 30 PSI Up to 500 PSI of discharge pressure can be produced (*with proper controls & modifications*). It has a 4.5" bore x 2.5" stroke and can be run at 400-900 RPM.

CHANGES

since previous printing dated December 2007:

Head unloader piping was modified.

TABLE OF CONTENTS

Serial Number Identification	2
Ordering Replacement Parts	2
Quin-Cip Lubricant	2
Crankcase Lubricant Capacity	2
Crankshaft Group	3-4
Crankcase Group	5-6
Bearing Carrier Group	7-8
Connecting Rod & Piston Groups	
low pressure	9-10
high pressure	11-12
Cylinder & Head Groups	13-16
Head Assemblies	17-18
Control Group	21
Gasket Set	22
Recommended Spare Parts	22
Decals	22

MODEL & SERIAL NUMBER IDENTIFICATION

Record of Change No.

Model & Serial Number Identification Tag

The serial number identification tag is located on the handhole plate side of the crankcase. *Fill in the numbers from compressor in the corresponding spaces provided here, and reference this page when ordering replacement parts.*

ORDERING REPLACEMENT PARTS

All replacement parts are to be ordered through an authorized Quincy Compressor Gas Application Distributor. **Insist on genuine Quincy parts only! Failure to do so may void warranty.**

Prompt service can be rendered on repair parts orders if the following information is given:

- Item 1)** the model number, record of change number, & serial number.
- Item 2)** the exact part number needed. (Do not order by item numbers.)
- Item 3)** the exact quantity needed.
- Item 4)** the preferred type of transportation.

WARNING !

Do not operate this compressor without a totally enclosed belt guard or any other required safety equipment.

QUIN-CIP® LUBRICANT

Refer to the chart below to order QUIN-CIP compressor lubricant from your local authorized Quincy distributor.

Package	Part No.	Description
Barrel	112542D068	55 gal., SAE 20
Pail	112542P068	5 gal., SAE 20
Gallon	112542G068	1 gal., SAE 20
Gallon Case	112542X068	(4)-1 gal., SAE 20
Quart	112542Q068	1 qt., SAE 20
Quart Case	112542C068	(12)-1 qt., SAE 20
Barrel	112543D100	55 gal., SAE 30
Pail	112543P100	5 gal., SAE 30
Gallon	112543G100	1 gal., SAE 30
Gallon Case	112543X100	(4)-1 gal., SAE 30
Quart	112543Q100	1 qt., SAE 30
Quart Case	112543C100	(12)-1 qt., SAE 30

CRANKCASE LUBRICANT CAPACITY

Model	Less Filter	With Filter
QRNG325	1½ Qts.	Add 10 oz.

CAUTION !

Refer to the QRNG Series Instruction Manual for vital lubrication information.

DANGER !

Air used for breathing or food processing must meet OSHA 1910.134 or FDA 21 CFR 178.3570 regulations. Failure to do so may cause severe injury or death.

CAUTION !

Follow all safety precautions outlined in the QRNG Series instruction manual.

CRANKSHAFT GROUP 1 10238

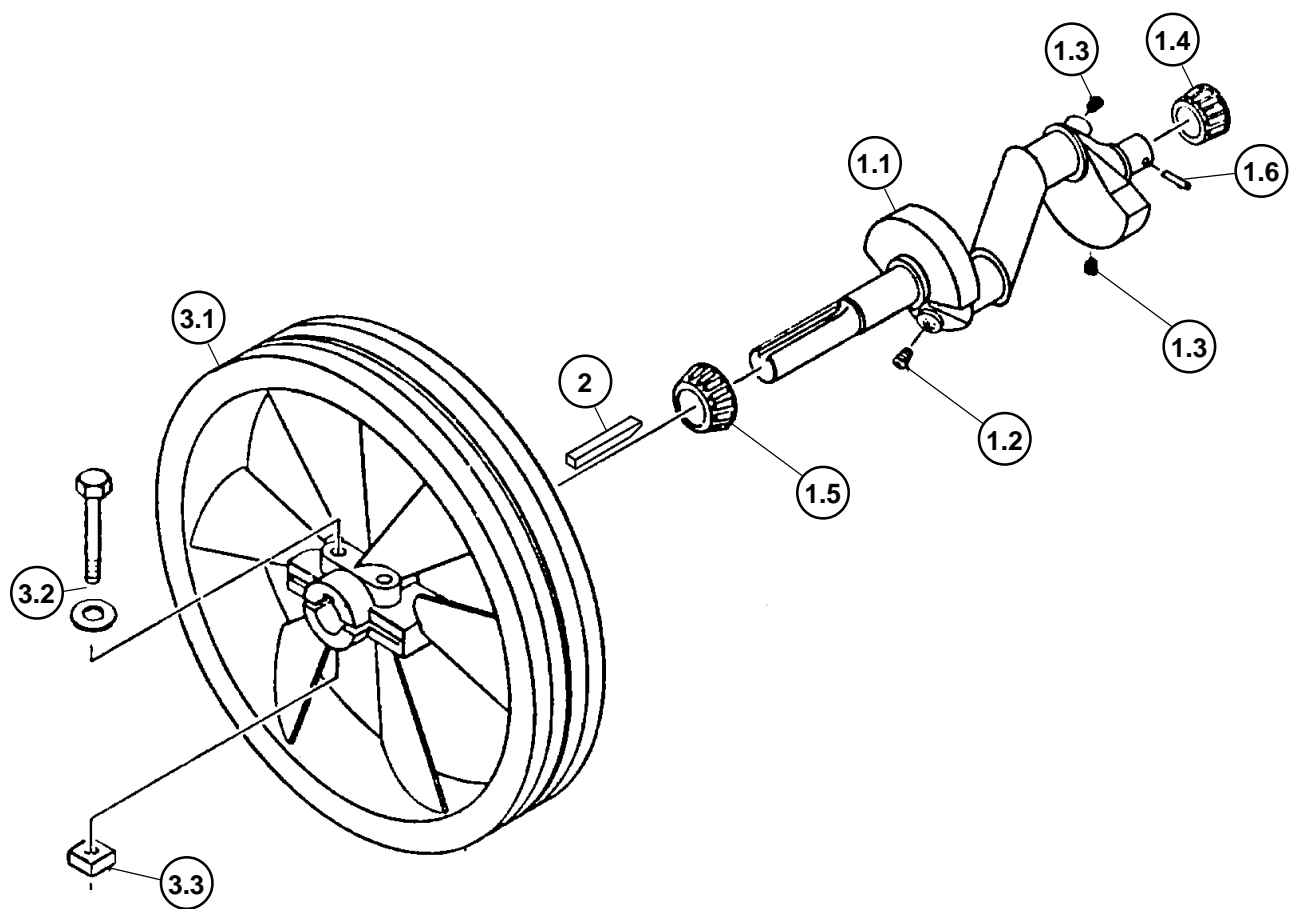

CRANKSHAFT GROUP 110238

Item Number	Qty.	Part Number	Description
1	1	110217	crankshaft assembly
1.1	1	110216	crankshaft (N.S.S.; order 110217)
1.2	1	110234	orifice, 1/8 npt
1.3	2	121160	pipe plug, 1/8 npt
1.4	1	2585	bearing cone
1.5	1	2788	bearing cone
1.6	1	110705-F15	pin
2	1	1844	key
3	1	110472X	sheave assembly
3.1	1	4126R	sheave , 16", 2 groove, B sect., CCW (N.S.S.; order 110472X)
3.2	2	123478-N23	hex. screw, 1/2-13 unc x 3.25, grade 5 (@ 75 ft.-lbs.)
3.3	2	124372-N02	square nut, 1/2-13 unc

N.S.S. = Not Sold Separate

@ Indicates torque value (dry threads)

Note: For reversal of compressor rotation refer to QRNG instruction manual.

CRANKCASE GROUP 111882-001

Item Number	Qty.	Part Number	Description
1	1	5503X003	crankcase assembly
1.1	1	5503-003	crankcase
1.2	1	2720	bearing cup
2	1	111876-1	gauge assembly
3	*	6294	bearing adj. shim, .005 steel
4	*	6294A	bearing adj. shim, .007 steel
5	*	6294B	bearing adj. shim, .020 steel
6	*	6294C	bearing adj. shim, .005 paper
7	*	6294D	bearing adj. shim, .002 steel
8	4	123478-L10	hex. screw, 3/8-16 unc x .75, grade 5 (@ 30 ft.-lbs.)
9	1	111877X	bearing adjustment plate assembly
9.1	1	111877	adjustment plate
9.2	1	111878	oil seal
10	1	22749-040	"o"ring, 1/16 wide x 3.00 o.d.
11	1	1301	pipe plug, 3/8 npt
12	1	6272	screen
13	1	6313-1	inlet screw gasket
14	1	22749-116	"o"ring, 3/32 wide x .94 o.d.
15	1	6275	gasket, inlet screw
‡ 16	1	6273	oil inlet screw
17	1	1840-1	inspection plate gasket
18	1	2322-1A	inspection plate (with oil filler)
19	6	123478-K12	hex. screw, 5/16-18 unc x 1.00, grade 5 (@ 12 ft.-lbs.)
20	1	112031X001	crankcase breather assembly
20.1	1	112031-001	breather body
20.2	1	112032-001	breather tube
20.3	1	5783-002	ball
20.4	1	110705-C11	roll pin, 3/32 x .81
21	1	110419-010	tube fitting, 90° male elbow, 3/8 tube x 3/8 npt
22	1	22749-112	"o"ring, 3/32 wide x .69 wide
‡ 23	1	8270	oil inlet tube

N.S.S. = Not Sold Separate

@ Indicates torque value (dry threads)

Note: For reversal of compressor rotation refer to QR-25 instruction manual.

‡ Assemble item 23 into item 16 with Loctite® 609.

BEARING CARRIER GROUP 111885-001

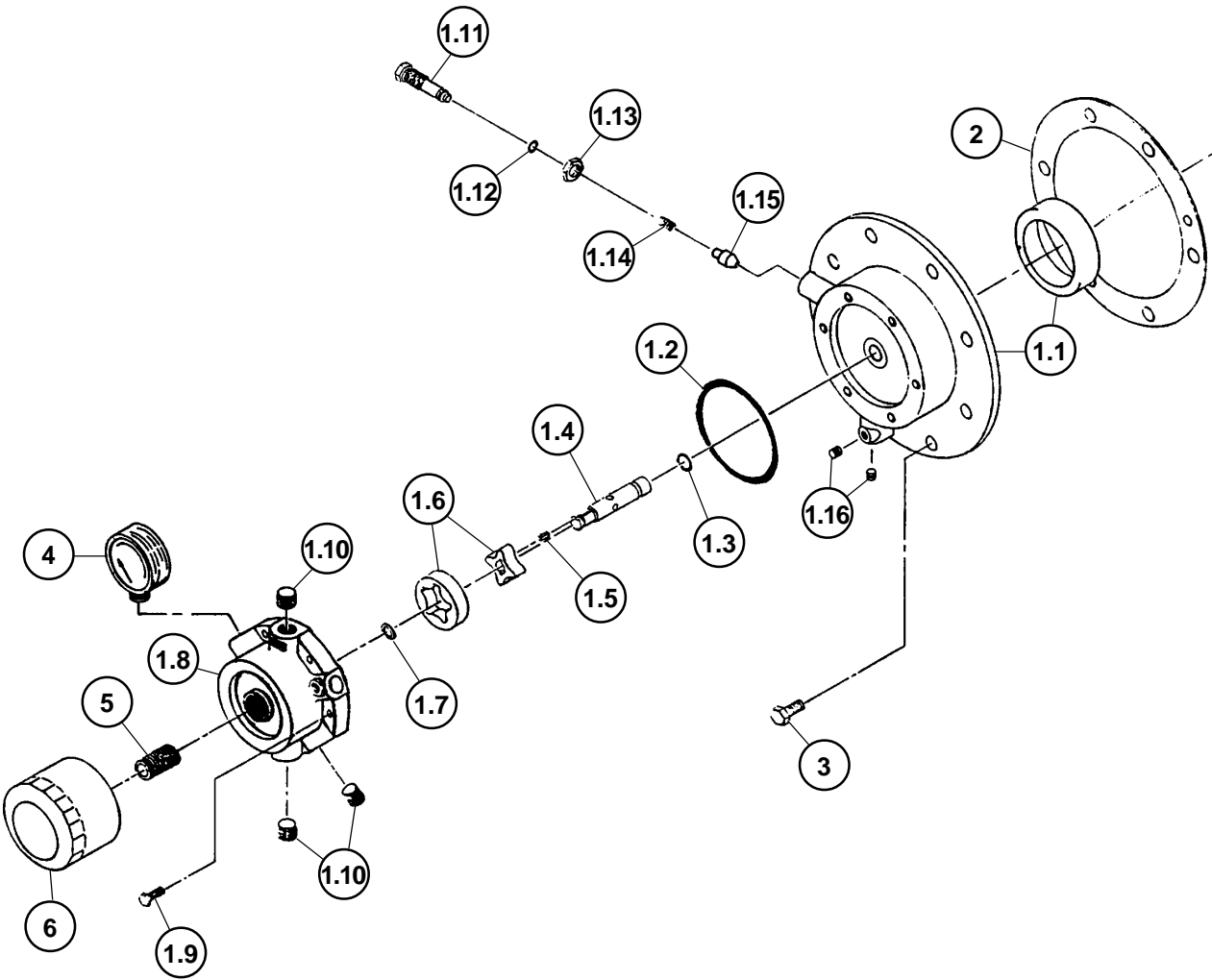

BEARING CARRIER GROUP 111885-001

Item Number	Qty.	Part Number	Description
1	1	111888-002	bearing carrier assembly (N.S.S.; order 111888G002)
1.1	1	110810	bearing carrier (N.S.S.; order 110810X003)
1.2	1	22749-152	"o"ring, 3/32 wide x 3.44 o.d.
1.3	1	22749-112	"o"ring, 3/32 wide x .69 o.d.
1.4	1	160002-002	driveshaft
1.5	1	160075-001	driveshaft key
1.6	1	160003	pump gerotor
1.7	1	6285	retaining ring
1.8	1	110813-001	oil pump housing
1.9	6	123777-J12	hex. screw, 1/4-20 unc x 1.00, grade 5 (@ 6 ft.-lbs.)
§ 1.10	3	2719	pipe plug, 1/4 npt, hex socket
1.11	1	5489	adjustment screw
1.12	1	22749-011	"o"ring, 1/16 wide x .44 o.d.
1.13	1	124369-P02	jamnut, 9/16-18 unf
1.14	1	1160	spring
1.15	1	112857	needle valve
§ 1.16	2	6565	hole plug
2	1	6312-1	bearing carrier gasket
3	6	123478-L12	hex. screw, 3/8-16 unc x 1.00, grade 5 (@ 30 ft.-lbs.)
4	1	110822	oil pressure gauge
5	1	110825	stud
6	1	110814	oil filter

Maintenance Parts

160078-001

Oil Pump Repair Kit

includes "o"rings, driveshaft, key, pump gerotor & retaining ring

111888G002

Replacement Bearing Carrier Assembly

includes bearing carrier assembly & bearing carrier gasket

N.S.S. = Not Sold Separate

@ Indicates torque value (dry threads). Tighten multiple bolts, capscrews & hex nuts in a criss-cross or alternating pattern. Bring each fastener to the recommended torque specification in even increments.

§ Install with Teflon® tape.

CONNECTING ROD & PISTON GROUP 112019-001

(low pressure)

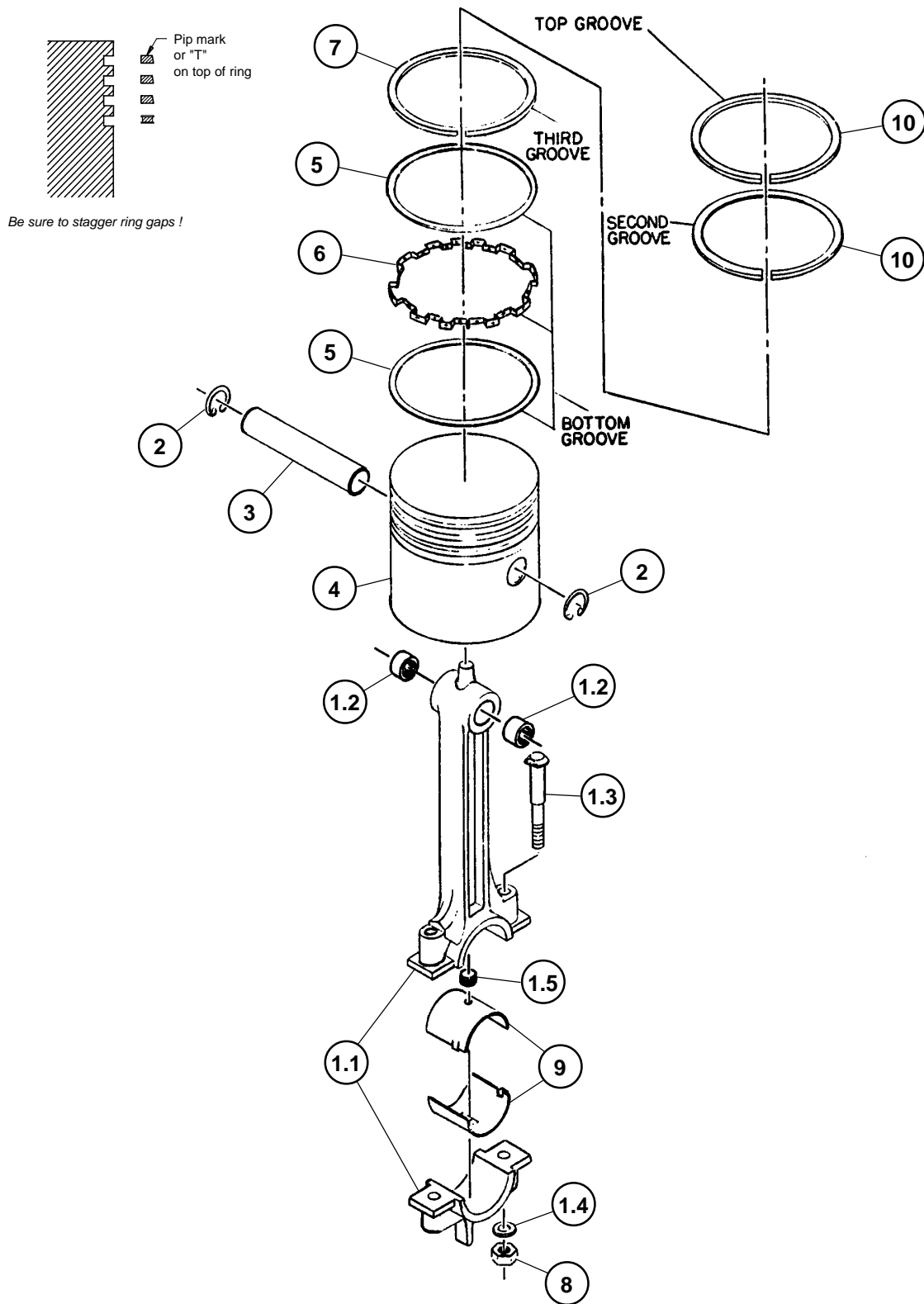

CONNECTING ROD & PISTON GROUP 112019-001

(low pressure)

Item Number	Qty.	Part Number	Description
1	1	112020-001	connecting rod assembly (N.S.S.; see maintenance parts)
1.1	1	112021	connecting rod (N.S.S.; see maintenance parts)
1.2	2	112022	needle bearing
1.3	2	3493	connecting rod bolt
1.4	2	1836	washer
1.5	1	110801-001	pipe plug orifice
2	2	128203-100	retaining ring
3	1	110190-018	piston pin
4	1	112023	compressor piston
5	2	112781	piston rail
6	1	112780	piston ring expander
7	3	7351	piston ring
8	2	124471-L08	locknut, 3/8-24 unf (@ 35 ft.-lbs.)
9	2	6444	connecting rod bearing insert (N.S.S.; see maintenance parts)
10	2	2584	piston ring
Maintenance Parts			
	1	112023-010	compressor piston (.010 oversize)
	1	112023-020	compressor piston (.020 oversize)
	1	8166A	Piston Ring Set (standard)
	1	4434-010	Piston Ring Set (.010 oversize, light blue color code)
	1	4434-020	Piston Ring Set (.020 oversize, yellow color code)
	* 1	6444PR	connecting rod bearing inserts (1 pair, standard size)
	* 1	6444-010PR	connecting rod bearing inserts (1 pair, .010 undersize)
		112023G001	Piston Assembly (standard) includes compressor piston, piston pin, ring set & retaining rings
		112023G010	Piston Assembly (.010 oversize) includes compressor piston, piston pin, ring set & retaining rings
		112023G020	Piston Assembly (.020 oversize) includes compressor piston, piston pin, ring set & retaining rings
		112021G	Replacement Connecting Rod Assembly (standard) includes connecting rod assemblies, con rod inserts & locknuts
		112021G010	Replacement Connecting Rod Assembly (.010 undersize) includes connecting rod assemblies, con rod inserts & locknuts

N.S.S. = Not Sold Separate

@ Indicates torque value (dry threads). Tighten multiple bolts, capscrews & hex nuts in a criss-cross or alternating pattern. Bring each fastener to the recommended torque specification in even increments.

* One pair required for each connecting rod assembly.

CONNECTING ROD & PISTON GROUP 112015-001

(high pressure)

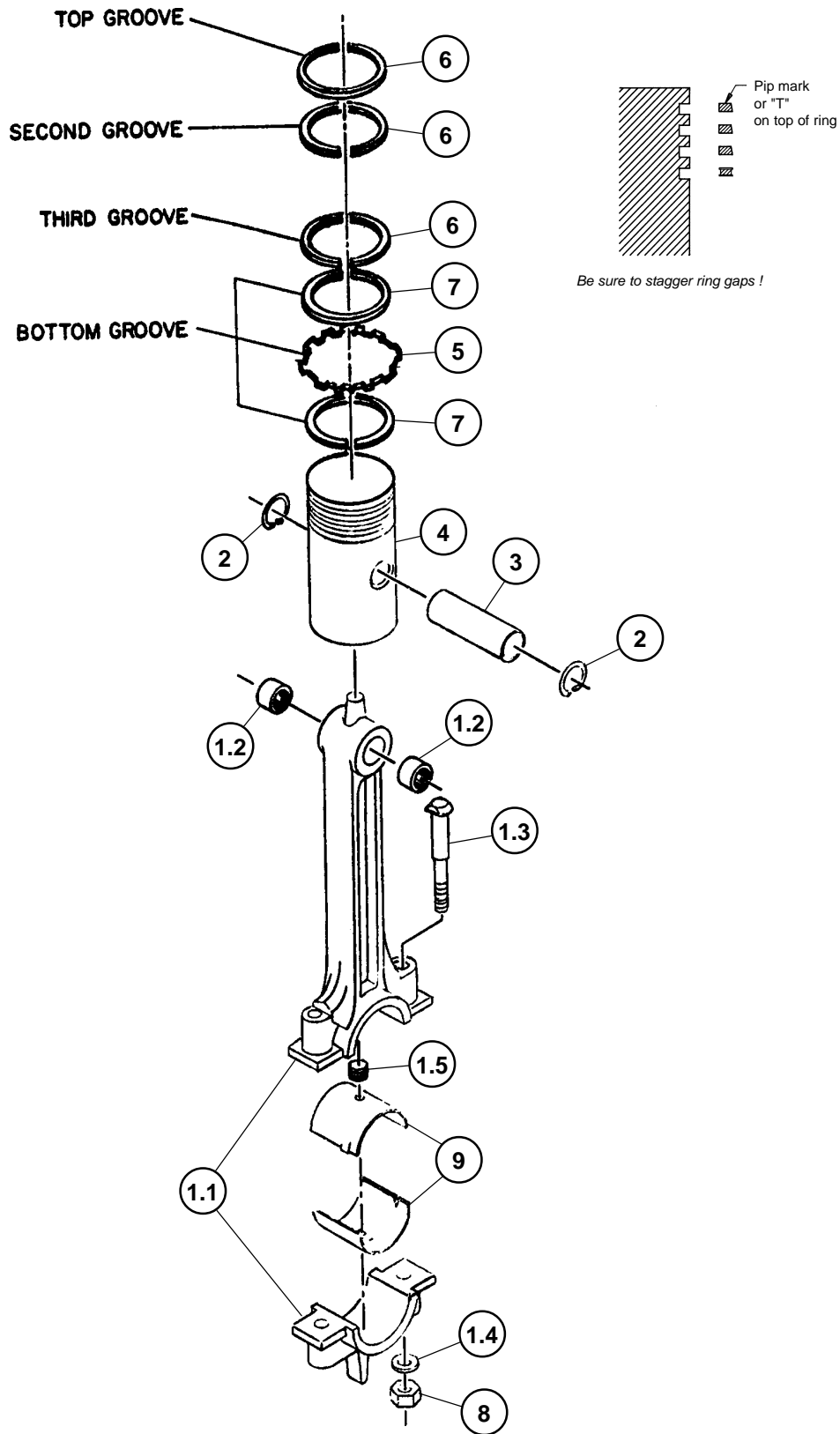

CONNECTING ROD & PISTON GROUP 112015-001

(high pressure)

Item Number	Qty.	Part Number	Description
1	1	112016-001	connecting rod assembly (N.S.S.; see maintenance parts)
1.1	1	112017	connecting rod (N.S.S.; see maintenance parts)
1.2	2	112018	needle bearing
1.3	2	3493	connecting rod bolt
1.4	2	1836	washer
1.5	1	110801-001	pipe plug orifice
2	2	8648	retaining ring
3	1	110190-021	piston pin
4	1	1530-001	piston , high pressure
5	1	111280	oil ring expander
6	3	1652	piston ring
7	2	111281	oil ring rail
8	2	124471-L08	locknut, 3/8-24 unf (@ 35 ft.-lbs.)
9	2	6444	connecting rod bearing insert (N.S.S.; see maintenance parts)
Maintenance Parts			
	1	1530-011	piston, high pressure (.010 oversize)
	1	1530-021	piston, high pressure (.020 oversize)
	1	8161A	Piston Ring Set (standard)
	1	4422-010	Piston Ring Set (.010 oversize, light blue color code)
	1	4422-020	Piston Ring Set (.020 oversize, yellow color code)
*	1	6444PR	connecting rod bearing inserts (1 pair, standard size)
*	1	6444-010PR	connecting rod bearing inserts (1 pair, .010 undersize)
		1530G001	Piston Assembly (standard) includes compressor piston, piston pin, ring set & retaining rings
		1530G010	Piston Assembly (.010 oversize) includes compressor piston, piston pin, ring set & retaining rings
		1530G020	Piston Assembly (.020 oversize) includes compressor piston, piston pin, ring set & retaining rings
		112017G	Replacement Connecting Rod Assembly (standard) includes con rod assemblies, inserts & locknuts
		112017G010	Replacement Connecting Rod Assembly (.010 undersize) includes con rod assemblies, inserts & locknuts

N.S.S. = Not Sold Separate

@ Indicates torque value (dry threads). Tighten multiple bolts, capscrews & hex nuts in a criss-cross or alternating pattern. Bring each fastener to the recommended torque specification in even increments.

* One pair required for each connecting rod assembly.

CYLINDER & HEAD GROUP 112024-001

(plain head)

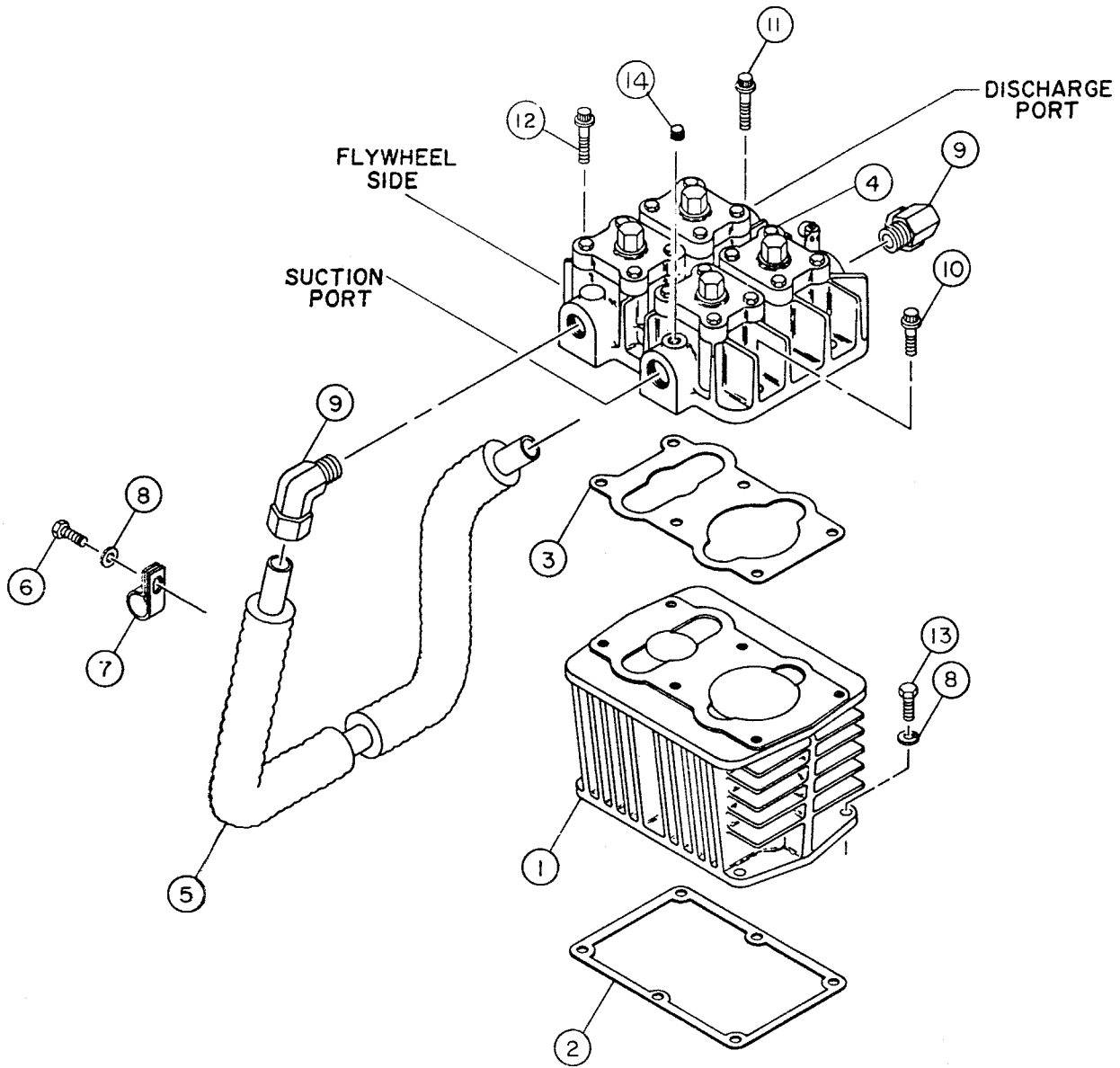

CYLINDER & HEAD GROUP 112024-001

(plain head)

Item Number	Qty.	Part Number	Description
1	1	6610-5HP	cylinder
2	1	1833-1	gasket
3	1	7000-1	gasket
4	1	112025-001	head assembly
5	1	111984	intercooler
6	1	123478-L10	hex. screw, 3/8-16 unc x .75, grade 5 (@ 30 ft.-lbs.)
7	1	6293	intercooler clamp
8	7	123115-06C	lockwasher, 3/8
9	2	110419-021	tube fitting, 90 male elbow 1 tube x 3/4 npt
10	2	90386-N14	counterbore screw, 1/2-13 unc x 1.25, grade 8 (@ 50 ft.-lbs.)
11	2	90386-N19	counterbore screw, 1/2-13 unc x 2.50, grade 8 (@ 50 ft.-lbs.)
12	2	90386-N18	counterbore screw, 1/2-13 unc x 2.25, grade 8 (@ 50 ft.-lbs.)
13	6	123478-L14	hex. screw, 3/8-16 unc x 1.25, grade 5 (@ 30 ft.-lbs.)
14	1	2719	pipe plug, 1/4 npt
			Maintenance Parts
	1	112025G002	Replacement Head Assembly includes gasket & head assembly

@ Indicates torque value (dry threads). Tighten multiple bolts, capscrews & hex nuts in a criss-cross or alternating pattern. Bring each fastener to the recommended torque specification in even increments.

CYLINDER & HEAD GROUP 112024-002

(head with unloaders)

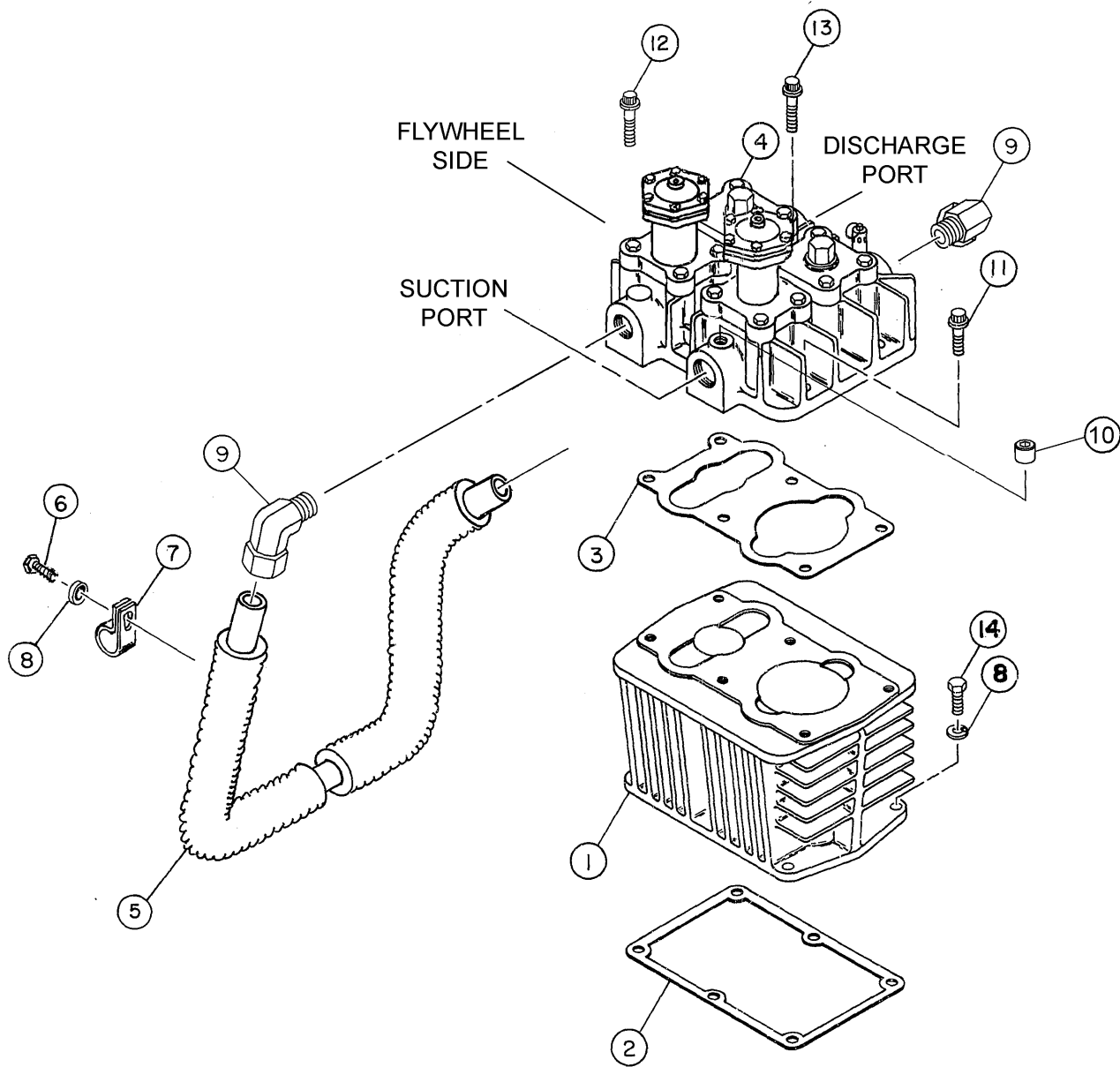

CYLINDER & HEAD GROUP 112024-002

(head with unloaders)

Item Number	Qty.	Part Number	Description
1	1	6610-5HP	cylinder
2	1	1833-1	gasket, cylinder to crankcase
3	1	7000-1	gasket
* 4	1	112025-003	head assembly (see page 25 for parts breakdown)
5	1	111984	intercooler (N.S.S.; order Intercooler Replacement Kit)
6	1	123478-L10	hex. screw, 3/8-16 unc x .75, grade 5 (@ 30 ft.-lbs.)
7	1	6293	clamp
8	7	123115-06C	lockwasher, 3/8
9	2	110419-021	fitting
10	1	2719	pipe plug 1/4 npt
11	2	90386-N14	counterbore screw, 1/2-13 unc x 1.25, grade 8 (@ 50 ft.-lbs.)
12	2	90386-N18	counterbore screw, 1/2-13 unc x 2.25, grade 8 (@ 50 ft.-lbs.)
13	2	90386-N19	counterbore screw, 1/2-13 unc x 2.50, grade 8 (@ 50 ft.-lbs.)
14	6	123478-L14	hex. screw, 3/8-16 unc x 1.25, grade 5 (@ 50 ft.-lbs.)
			Maintenance Parts
	1	112025G003	Replacement Head Assembly includes head assy., head gasket
	1	111984K	Intercooler Replacement Kit includes intercooler and sleeve fittings

N.S.S. = Not Sold Separate

@ Indicates torque value (dry threads). Tighten multiple bolts, capscrews & hex nuts in a criss-cross or alternating pattern. Bring each fastener to the recommended torque specification in even increments.

* For head and cylinder replacement, order 111496HPS head in lieu of 111496HP head, and 6610-5HPS cylinder in lieu of 6610-5HP cylinder.

HEAD ASSEMBLY 112025-001

(plain head)

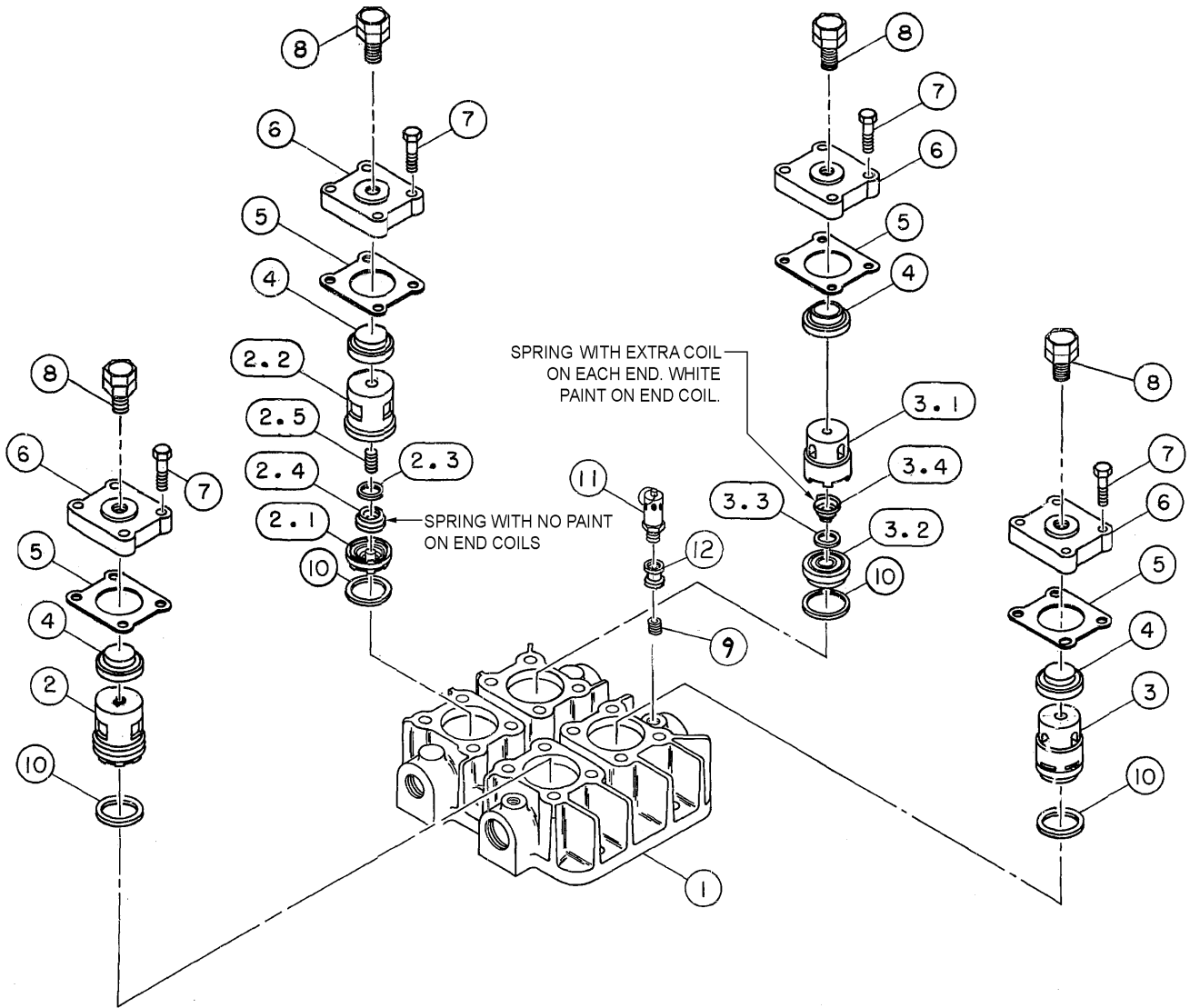

HEAD ASSEMBLY 112025-001

(plain head)

Item Number	Qty.	Part Number	Description
** 1	1	111496HP	head
2	2	7277X1	valve assembly
2.1	1	7277	valve bumper
2.2	1	1815	valve seat
2.3	1	1846	valve disc
2.4	1	7270	valve spring
2.5	1	1849	stud
3	2	7271X004	discharge valve assembly
3.1	1	7271-004	discharge valve bumper
3.2	1	1819-002	discharge valve seat
3.3	1	1846	valve disc
3.4	1	7270-2	valve spring
4	4	110639	spacer
5	4	1852-1	gasket, valve cover
6	4	5906	valve cover plate
* 7	16	7480	hex. screw, 7/16-14 unc x 1.38, grade 5 (@ 50 ft.-lbs.)
* 8	4	114545-R15	screw and nut assembly, 3/4-16 unf x 1.50, grade 5 (screw @ 60 ft.-lbs. - nut @ 50 ft.-lbs.)
9	1	2177	pipe nipple, 1/4 npt x close
10	4	1848-001	gasket, valve
11	1	111425-270	pressure relief valve
12	1	124699-007	pipe coupling, 1/4 npt

Maintenance Parts

7277G

Replacement Suction Valve Assembly

includes suction valve assembly & valve gasket

7271G

Replacement Discharge Valve Assembly

includes discharge valve assembly & valve gasket

@ Indicates torque value (dry threads). Tighten multiple bolts, capscrews & hex nuts in a criss-cross or alternating pattern. Bring each fastener to the recommended torque specification in even increments.

* Tighten & torque valve cover plate screws (item 7) before tightening valve clamp screws (item 8).

** For head replacement order 111496HPS head in lieu of 111496HP head.

HEAD ASSEMBLY 112025-003

(head with unloaders)

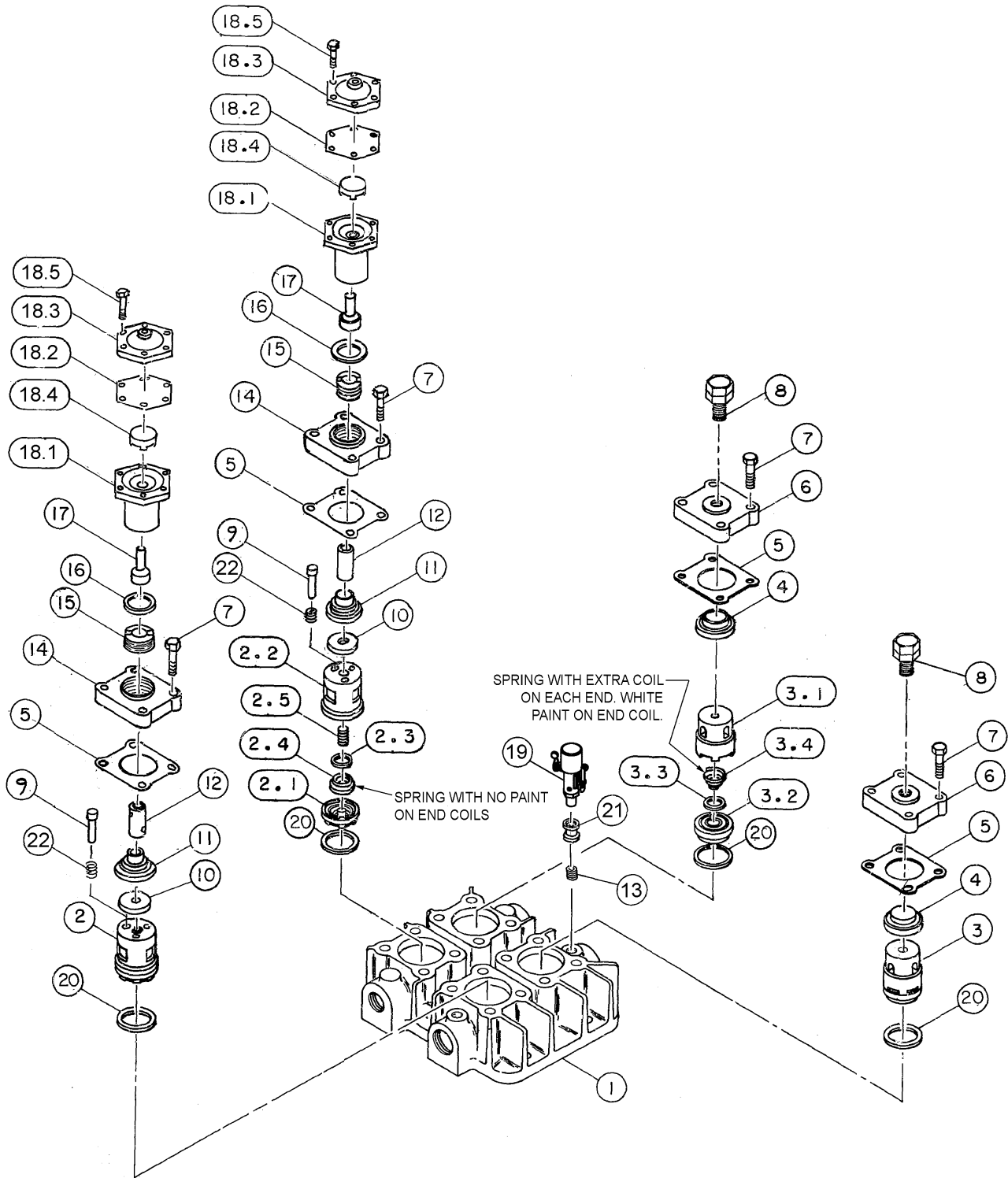

HEAD ASSEMBLY 112025-003

(head with unloaders)

Item Number	Qty.	Part Number	Description
* 1	1	111496HP	head
2	2	7277X1	valve assembly
2.1	1	7277	valve bumper
2.2	1	1815	seat
2.3	1	1846	valve disc
2.4	1	7270	valve spring
2.5	1	1849	stud
3	2	7271X004	discharge valve assembly
3.1	1	7271-004	discharge valve bumper
3.2	1	1819-002	discharge valve seat
3.3	1	1846	valve disc
3.4	1	7270-2	valve spring
4	2	110639	spacer
5	4	1852-1	gasket
6	2	5906	valve cover plate
‡ 7	16	7480	hex. screw, 7/16-14 unc x 1.38, grade 5 (@ 50 ft.-lbs.)
** 8	2	114545-R15	screw & nut assembly (screw @ 60 ft.-lbs. - nut @ 50 ft.-lbs.)
9	6	1857	valve pin
10	2	6925	platform
11	2	6964	spacer
12	2	6965-002	pin
13	1	2177	nipple
14	2	6928	plate
15	2	3008	holddown screw (@ 70 ft.-lbs.)
16	2	1556	gasket
17	2	7532X1	unloader piston assembly
18	2	40055	unloader assembly (@ 75 ft.-lbs.) (N.S.S.; order 7483X1)
18.1	1	7483	unloader body
18.2	1	1855	diaphragm
18.3	1	1818B	diaphragm cover plate
18.4	1	5910	diaphragm disc
18.5	6	7499	hex. screw, 1/4-20 unc x .75, grade 2 (@ 72 in.-lbs.)
19	1	111425-270	pressure relief valve
20	4	1848-001	gasket
21	1	124699-007	coupling
22	6	6610	valve spring

Maintenance Parts

1	111496HPS	Replacement Head
1	7277G	Replacement Suction Valve Assembly includes suction valve assy. & valve gasket
2	7277GU	Replacement Suction Valve Assembly includes suction valve assy., valve gasket, valve pins & valve springs
2	7271G	Replacement Discharge Valve Assembly includes discharge valve assy. & valve gasket
2	7483X1	Replacement Unloader Assembly includes unloader assy. (40055), unloader piston assy., valve gasket & pipe plug

Parts for use with diester or phosphate ester synthetic based lubricants

18.2	1	1855S	diaphragm
------	---	-------	-----------

N.S.S. = Not Sold Separate

@ Indicates torque value (dry threads). Tighten multiple bolts, capscrews & hex nuts in a criss-cross or alternating pattern.

Bring each fastener to the recommended torque specification in even increments.

* For head replacement, order 111496HPS head in lieu of 111496HP head.

‡ Tighten and torque valve cover plate hex screws (item 7) prior to tightening valve clamp hex screws (item 8).

** Install with Loctite® 246 applied to threads.

CONTROL GROUP 116269-001

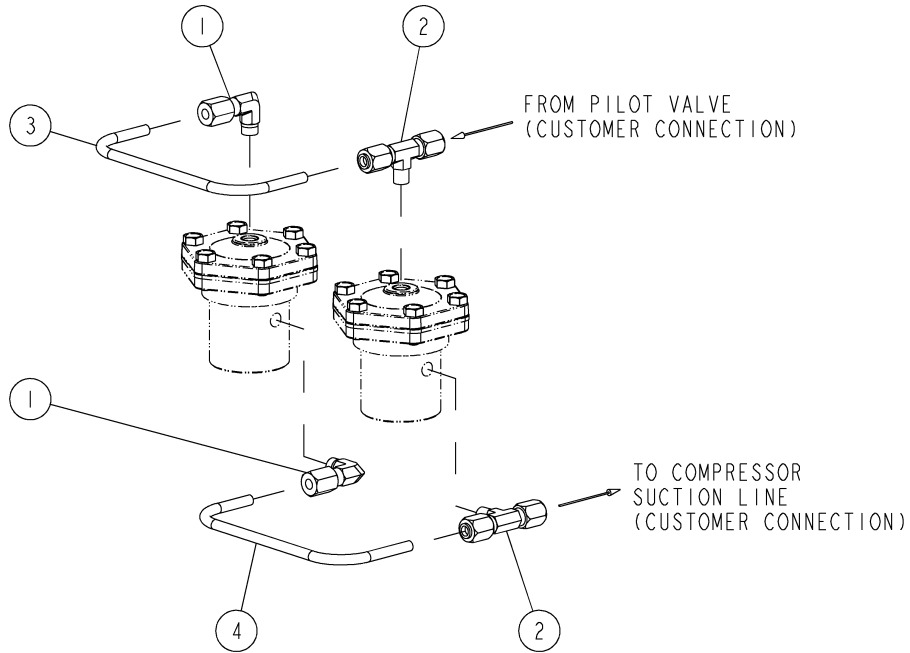

116269-001 GROUP, CONTROL, QRNG UNLOADERS			
ITEM	PART NUMBER	QTY	DESCRIPTION
1	110419-004	2	TUBE FITTING, 90 MALE ELBOW, 1/4 TUBE X 1/8 NPT
2	116268-002	2	TUBE FITTING, MALE BRANCH TEE, 1/4T X 1/8P
3	110421	1	1/4" STEEL TUBE (1 FT)
4	110421	1	1/4" STEEL TUBE (1 FT)

Recommended Spare Parts			
Item #	Qty.	Part Number	Description
	2	7277G	replacement suction valve assy
	2	7271G	replacement discharge valve assy
	1	110822	pressure gauge
	1	160078-001	oil pump repair kit
	1	7126G	gasket set

Gasket Set 7126G			
Item #	Qty.	Part Number	Description
	1	1833-1	gasket, cylinder to crankcase
	1	1840-1	gasket, inspection plate
	4	1848-001	gasket
	4	1852-1	gasket
	2	6294	bearing adj. shim, .005 steel
	2	6294A	bearing adj. shim, .007 steel
	1	6294B	bearing adj. shim, .020 steel
	6	6294C	bearing adj. shim, .005 paper
	2	6294D	bearing adj. shim, .002 steel
	1	6312-1	gasket, bearing carrier
	1	7000-1	gasket

"O"Ring Kit 110290G001			
Item #	Qty.	Part Number	Description
	2	22749-112	"o"ring
	1	22749-116	"o"ring
	1	22749-011	"o"ring
	1	22749-152	"o"ring
	1	111878	oil seal
	1	22749-040	"o"ring
	1	112033-908	"o"ring

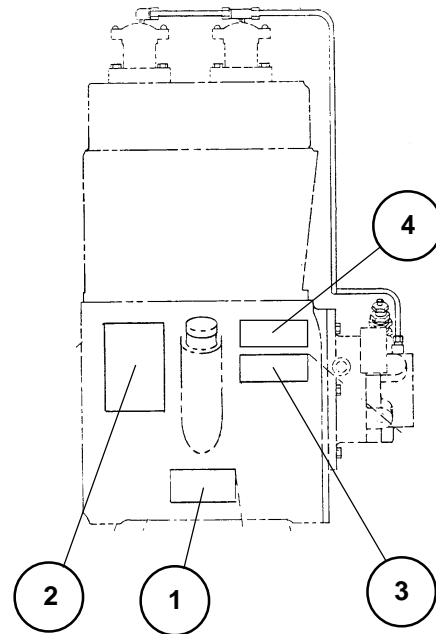

Decals			
Item #	Qty.	Part Number	Description
	1	110831	serial number & nameplate
	2	127889-A	decal, CAUTION!/manual/ "Failure to follow..."
	3	127889-B	decal, DANGER! / "Air used for breathing..."
	4	113387	decal, CAUTION/Do not remove dipstick....

QUINCY COMPRESSOR

STANDARD TERMS AND CONDITIONS

LEGAL EFFECT: Except as expressly otherwise agreed to in writing by an authorized representative of Seller, the following terms and conditions shall apply to and form a part of this order and any additional and/or different terms of Buyer's purchase order or other form of acceptance are rejected in advance and shall not become a part of this order.

The rights of Buyer hereunder shall be neither assignable nor transferable except with the written consent of Seller.

This order may not be canceled or altered except with the written consent of Seller and upon terms which will indemnify Seller against all loss occasioned thereby. All additional costs incurred by Seller due to changes in design or specifications, modification of this order or revision of product must be paid for by Buyer.

In addition to the rights and remedies conferred upon Seller by this order, Seller shall have all rights and remedies conferred at law and in equity and shall not be required to proceed with the performance of this order if Buyer is in default in the performance of such order or of any other contract or order with seller.

TERMS OF PAYMENT: Unless otherwise specified in the order acknowledgment, the terms of payment shall be 1% 15, net forty-five (45) days after shipment. These terms shall apply to partial as well as complete shipments. If any proceeding be initiated by or against Buyer under any bankruptcy or insolvency law, or in the judgment of Seller the financial condition of Buyer, at the time the equipment is ready for shipment, does not justify the terms of payment specified, Seller reserves the right to require full payment in cash prior to making shipment. If such payment is not received within fifteen (15) days after notification of readiness for shipment, Seller may cancel the order as to any unshipped item and require payment of its reasonable cancellation charges.

If Buyer delays shipment, payments based on date of shipment shall become due as of the date when ready for shipment. If Buyer delays completion of manufacture, Seller may elect to require payment according to percentage of completion. Equipment held for Buyer shall be at Buyer's risk and storage charges may be applied at the discretion of Seller.

Accounts past due shall bear interest at the highest rate lawful to contract for but if there is no limit set by law, such interest shall be eighteen percent (18%). Buyer shall pay all cost and expenses, including reasonable attorney's fees, incurred in collecting the same, and no claim, except claims within Seller's warranty of material or workmanship, as stated below, will be recognized unless delivered in writing to Seller within thirty (30) days after date of shipment.

TAXES: All prices exclude present and future sales, use, occupation, license, excise, and other taxes in respect of manufacture, sales or delivery, all of which shall be paid by Buyer unless included in the purchase price at the proper rate or a proper exemption certificate is furnished.

ACCEPTANCE: All offers to purchase, quotations and contracts of sales are subject to final acceptance by an authorized representative at Seller's plant.

DELIVERY: Except as otherwise specified in this quotation, delivery will be F. O. B. point of shipment. In the absence of exact shipping instruction, Seller will use its discretion regarding best means of insured shipment. No liability will be accepted by Seller for so doing. All transportation charges are at Buyer's expense. Time of delivery is an estimate only and is based upon the receipt of all information and necessary approvals. The shipping schedule shall not be construed to limit seller in making commitments for materials or in fabricating articles under this order in accordance with Seller's normal and reasonable production schedules.

Seller shall in no event be liable for delays caused by fires, acts of God, strikes, labor difficulties, acts of governmental or military authorities, delays in transportation or procuring materials, or causes of any kind beyond Seller's control. No provision for liquidated damages for any cause shall apply under this order. Buyer shall accept delivery within thirty (30) days after receipt of notification of readiness for shipment. Claims for shortages will be deemed to have been waived if not made in writing with ten (10) days after the receipt of the material in respect of which any such shortage is claimed. Seller is not responsible for loss or damage in transit after having received "In Good Order" receipt from the carrier. All claims for loss or damage in transit should be made to the carrier.

TITLE & LIEN RIGHTS: The equipment shall remain personal property, regardless of how affixed to any realty or structure. Until the price (including any notes given therefore) of the equipment has been fully paid in cash, Seller shall, in the event of Buyer's default, have the right to repossess such equipment.

PATENT INFRINGEMENT: If properly notified and given an opportunity to do so with friendly assistance, Seller will defend Buyer and the ultimate user of the equipment from any actual or alleged infringement of any published United States patent by the equipment or any part thereof furnished pursuant hereto (other than parts of special design, construction, or manufacture specified by and originating with Buyer), and will pay all damages and costs awarded by competent court in any suit thus defended or of which it may have had notice and opportunity to defend as aforesaid.

STANDARD WARRANTY: Seller warrants that products of its own manufacture will be free from defects in workmanship and materials under normal use and service for the period specified in the product instruction manual. Warranty for service parts will be Ninety (90) days from date of factory shipment. Electric Motors, gasoline and diesel engines, electrical apparatus and all other accessories, components and parts not manufactured by Seller are warranted only to the extent of the original manufacturer's warranty.

Notice of the alleged defect must be given to the Seller, in writing with all identifying details including serial number, type of equipment and date of purchase within thirty (30) days of the discovery of the same during the warranty period.

Seller's sole obligation on this warranty shall be, at its option, to repair or replace or refund the purchase price of any product or part thereof which proves to be defective. If requested by Seller, such product or part thereof must be promptly returned to seller, freight prepaid, for inspection.

Seller warrants repaired or replaced parts of its own manufacture against defects in materials and workmanship under normal use and service for ninety (90) days or for the remainder of the warranty on the product being repaired.

This warranty shall not apply and Seller shall not be responsible or liable for:

- (a) Consequential, collateral or special losses or damages;
- (b) Equipment conditions caused by fair wear and tear, abnormal conditions of use, accident, neglect or misuse of equipment, improper storage or damage resulting during shipping;
- (c) Deviation from operating instructions, specifications or other special terms of sale;
- (d) Labor charges, loss or damage resulting from improper operation, maintenance or repairs made by person(s) other than Seller or Seller's authorized service station.

In no event shall Seller be liable for any claims whether arising from breach of contract or warranty or claims of negligence or negligent manufacture in excess of the purchase price.

THIS WARRANTY IS THE SOLE WARRANTY OF SELLERS AND ANY OTHER WARRANTIES, WHETHER EXPRESS OR IMPLIED IN LAW OR IMPLIED IN FACT, INCLUDING ANY WARRANTIES OF MERCHANTABILITY AND FITNESS FOR PARTICULAR USE ARE HEREBY SPECIFICALLY EXCLUDED.

LIABILITY LIMITATIONS: Under no circumstances shall the Seller have any liability for liquidated damages or for collateral, consequential or special damages or for loss of profits, or for actual losses or for loss of production or progress of construction, whether resulting from delays in delivery or performance, breach of warranty, negligent manufacture or otherwise.

ENVIRONMENTAL AND OSHA REQUIREMENTS: At the time of shipment of the equipment from the factory, Quincy Compressor / Ortman Fluid Power will comply with the various Federal, State and local laws and regulations concerning occupational health and safety and pollution. However, in the installation and operation of the equipment and other matters over which the seller has no control, the Seller assumes no responsibility for compliance with those laws and regulations, whether by the way of indemnity, warranty or otherwise.

June 30, 2003



an EnPro Industries company

Reciprocating / Systems: 217.222.7700
Air Master 217.277.0270
E-mail: info@quincycompressor.com
Website: quincycompressor.com
quincyairmaster.com



© 2006 Quincy Compressor, an EnPro Industries company
All Rights Reserved. Litho in U.S.A.