

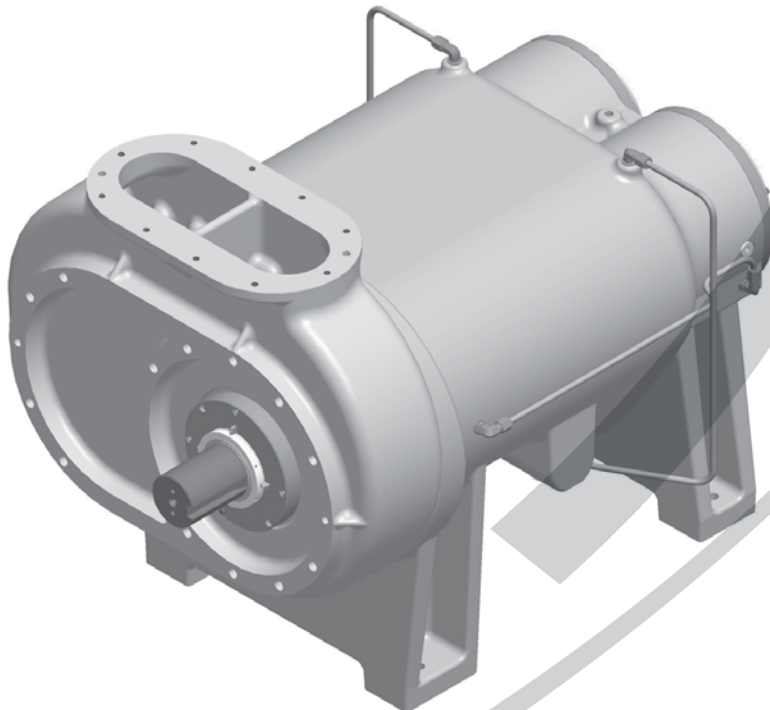

an EnPro Industries company

QSG Series

Rotary Screw Gas Compression Modules



Instruction Manual

This manual contains important safety information and should be made available to all personnel who operate and/or maintain this product. Carefully read this manual before attempting to operate or perform maintenance on this equipment.

Manual No. 65065-2A

March 2008 Edition

Table of Contents

Section I - General Information

Safety Alert Symbols	1
Safety Precautions	2
Spare Parts Ordering Information	3
Serial/Model Identification Plate	4
Serial Plate Model Designation	4
Standard Warranty.....	5

Section II - Description

General Description	6
The Compression Cycle	6
Volume Ratio (Vi)	7
Capacity Control	7
Compressor Performance Program (Q\$ize).....	7
Engine Adapters.....	8
Fluid Flow	8
Compressor System	8

Section III - Installation

Receiving	12
Freight Damage	13
Location.....	14
Mounting.....	15
System Components	15

Section IV - Operating Procedures

Prior to Starting	16
Starting the Compressor	17
Daily Starting Checklist	17
Stopping the Compressor.....	17

Section V - Servicing

Preparing for Maintenance or Service	18
Maintenance Schedule	19
Mechanical Shaft Seal Installation	20
Compressor Drive.....	23

Section VI - Troubleshooting

Troubleshooting	24-25
-----------------------	-------

Appendix A - Technical Data

High Pressure	26
Low Pressure	27

Appendix B - Maintenance Record

Maintenance Record	28-29
--------------------------	-------



quincycompressor.com

Thank you for purchasing a Quincy Compressor QSG gas compression module.

-
- Safety Alert Symbols
 - Safety Precautions
 - Spare Parts Ordering Information
 - Serial/Model Identification Plate
 - Standard Warranty

Safety Alert Symbols

IMPORTANT!

Throughout this manual we have identified key hazards. The following symbols identify the level of hazard seriousness:



DANGER!

This symbol identifies immediate hazards which ***will*** result in severe personal injury, death or substantial property damage.



WARNING!

This symbol identifies hazards or unsafe practices which ***could*** result in personal injury, death or substantial property damage.



DANGER!

This symbol identifies life threatening electrical voltage levels which ***will*** result in severe personal injury or death. All electrical work ***must*** be performed by a qualified electrician.



CAUTION!

Identifies hazards or unsafe practices which ***could*** result in minor personal injury or property damage.



NOTICE!

Identifies important installation, operation or maintenance information which is not hazard related.

Section I - General Information

Safety Precautions

Each section of this instruction manual, as well as any instructions supplied by manufacturers of supporting equipment, should be read and understood prior to starting the compressor. If there are any questions regarding any part of the instructions, please call your local Quincy Compressor Authorized Gas Packager, or the Quincy Compressor factory before creating a potentially hazardous situation. Life, limb, or equipment could be saved with a simple phone call.

Compressors are precision high speed mechanical equipment requiring caution in operation to minimize hazard to property and personnel. There are many obvious safety rules that must be observed in the operation of this type of equipment.

Listed below are some, but not all, safety precautions that must be observed with compressors and compressor systems.



WARNING!

Failure to follow any of these precautions may result in severe personal injury, death, property damage and/or compressor damage.



WARNING!

QSG gas compression modules are shipped from the factory without lubricating fluid. An appropriate lubricating fluid must be added to the compressor package prior to start-up to prevent damaging the QSG gas compression module.

- ◆ Transfer of toxic, dangerous, flammable or explosive substances using Quincy Compressor products is at the user's risk.

- ◆ Turn off and lockout/tagout (per OSHA regulation 1910.147) the main power disconnect switch before attempting to work on or perform any maintenance on the unit.
- ◆ Do not attempt to service any part of the unit while it is operating.
- ◆ Per OSHA regulation 1910.147, relieve the system of all pressure before attempting to service any part of the unit.
- ◆ Do not operate the unit with any of its safety guards, shields, or screens removed.
- ◆ Allow ample time for the compressor to cool before performing service.
- ◆ Do not remove or paint over any safety decals or instructional materials attached to the compressor. Lack of information regarding hazardous conditions can cause property damage or personal injury.
- ◆ Periodically check all pressure relief valves for proper operation.
- ◆ Do not change the pressure setting of the pressure relief valve, restrict the function of the pressure relief valve, or replace the pressure relief valve with a plug.
- ◆ Do not install a shutoff valve in the gas compression module discharge line without first installing a pressure relief valve of proper size and design between the shutoff valve and the gas compression module.
- ◆ Do not use plastic pipe, rubber hose, or lead-tin soldered joints in any part of the compressed gas system.
- ◆ Alterations must not be made to a QSG gas compression module without Quincy Compressor's approval.

- ◆ Be sure that all tools, shipping and installation debris have been removed from the compressor and installation site prior to starting the compressor.
- ◆ Do not operate the compressor in excess of the ASME pressure vessel rating for the receiver or the service rating of the compressor, whichever is lower.
- ◆ Make a general overall inspection of the unit daily and correct any unsafe situations. All fasteners and fittings must be kept tight.
- ◆ Reckless behavior of any kind involving compressed gas is dangerous and can cause very serious injury to the participants.
- ◆ Provisions should be made to have this instruction manual readily available to the operator and maintenance personnel. If for any reason any part of the manual becomes illegible or the manual is lost, have it replaced immediately. The instruction manual should be read periodically to refresh one's memory. It may prevent a serious or fatal accident.
- ◆ Never use a flammable or toxic solvent for cleaning the inlet filter or any parts.



WARNING!

No smoking in any area near a natural gas compressor! Natural gas is highly explosive.

NOTICE!

Every effort has been taken to ensure complete and correct instructions have been included in this manual, however, possible product updates and changes may have occurred since this printing. Quincy Compressor® reserves the right to change specifications without incurring any obligation for equipment previously or subsequently sold. Not responsible for typographical errors.



WARNING!

Do not operate a QSG gas compression module in excess of its published rating listed in Appendix A-Technical Data.

The owner, lessor or operator of any QGS gas compression module manufactured by Quincy Compressor is hereby warned that failure to observe the safety precautions and procedures outlined in this manual may result in serious personal injury, damage to property, and may void your warranty. Quincy Compressor must authorize all warranty service. Before contacting your Quincy Authorized Gas Packager or the factory, check the maintenance requirements and the troubleshooting guide for your compressor. Most warranty issues can be resolved by following proper maintenance procedures.

NOTICE!

These instructions, precautions and descriptions cover standard Quincy manufactured QSG Series gas compression modules. As a service to our customers, we often modify or construct gas compression modules to customer specifications. This manual may not be appropriate in those cases.

Section I - General Information

Spare Parts Ordering Information

Quincy Compressor maintains replacement parts for Quincy gas compression modules and accessories. A repair parts list is shipped with all new compression

modules. Order parts from your Quincy Authorized Gas Packager. Use only genuine Quincy replacement parts. Failure to do so may void warranty.

Serial/Model Identification Plate

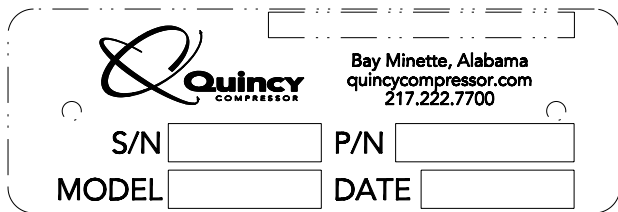

Reference to the machine MODEL, SERIAL NUMBER and DATE OF ORIGINAL START-UP must be made in all communication relative to parts orders. A model/serial number plate is located on top of the gas compression module housing.

Serial Plate Model Designation

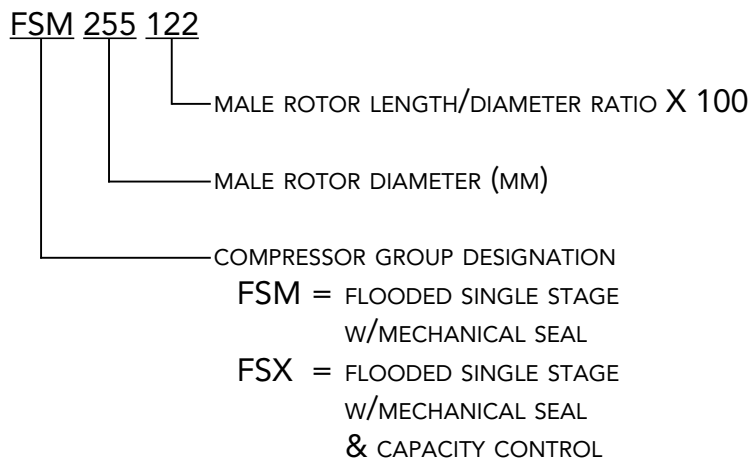

Standard Warranty

Quincy Compressor® Industrial Rotary Screw Products

QSG Series Gas Compression Modules

GENERAL PROVISIONS

Quincy Compressor (Seller) warrants to each retail purchaser (Purchaser) products of the Seller's own manufacture against defects in material and workmanship. With respect to products not manufactured by the Seller, the Seller will, if practical, pass along the warranty of the original manufacturer.

The Seller's sole obligation under this warranty shall be, at its option, to repair, replace, or refund the purchase price of any product or part thereof which is deemed to be defective, provided the Purchaser meets all of the applicable requirements of this warranty and none of the limitations apply.

WARRANTY PERIODS

QSG Gas Compression Modules

Seller warrants the gas compression module (materials and workmanship only) for one (1) year from date of purchase (proof of purchase required). If proof of purchase is not available, warranty coverage begins on date of shipment from the factory.

No reimbursement for travel is allowed.

Replacement Parts

Seller warrants repaired or replaced parts of its own manufacture against defects in material and workmanship under normal use and service for ninety (90) days, or for the remainder of the warranty on the product being repaired, whichever is longer.

Parts purchased outside the compressor's warranty period are warranted for ninety (90) days from date of purchase (proof of purchase date required). If proof of purchase is not available, warranty coverage begins on date of shipment from the factory.

Normal maintenance items and procedures are not warranted unless found to be defective in material or workmanship, i.e. but not limited to filters, gaskets, rings, valves and control lines.

LIMITATIONS

Notice of the alleged defect must be given to the Seller in writing with all identifying details, including serial number, model number, type of equipment and date of purchase within thirty (30) days of discovery of same during the warranty period.

If requested by Seller, such product or product thereof must be promptly returned to Seller (freight prepaid) for inspection.

The Seller must have the warranty registration card on file with Quincy Compressor within ten (10) days of start-up or the warranty may be declared null and void.

The above warranties shall not apply and Seller shall not be responsible nor liable for:

- (a) Consequential, collateral or special losses or damages.
- (b) Equipment conditions caused by fair wear and tear, abnormal conditions, accident, neglect or misuse of equipment, improper storage or damages resulting during shipment.
- (c) Deviation from operating instructions, specifications or other terms of sales.
- (d) Labor charges, loss or damage resulting from improper operation, maintenance or repairs made by person(s) other than Seller or Seller's authorized service station.
- (e) Improper application or installation of product.
- (f) Compression of other than sweet, dry natural gas as defined by NACE MRO 175.
- (g) Inadequate filtration (scrubbing) of inlet natural gas.
- (h) Failure to maintain adequate fluid flow capacity injected into the gas Compression module.

DISCLAIMER

In no event shall Seller be liable for any claims, whether arising from breach of contract or warranty or claims of negligence or negligent manufacture, in excess of the purchase price.

This warranty is the sole warranty of Seller and any other warranties, express, implied in law or implied in fact, including any warranties of merchantability and fitness for particular use, are hereby specifically excluded.

Section II - Description

- General Description
- The Compression Cycle
- Volume Ratio (V_r)
- Capacity Control
- Compressor Performance Program (Q\$ize)
- Engine Adapters
- Fluid Flow
- Compressor System

General Description

QSG gas compression modules are single stage, positive displacement rotary screw gas compression modules, which are available with two discrete internal (built-in) volume ratios to accommodate a wide range of pressure ratios. The rotary screw gas compression modules contain two precision-machined rotors that operate in cast iron housings. The drive (input) shaft

is an integral extension of the male rotor. The inlet port is located on the top of the compression module, while the discharge port is located at the end opposite of the drive shaft. Each compression module is available with a positive displacement fluid pump, driven from the male or female rotor discharge shaft, to lubricate both the rotors and bearings.

The Compression Cycle

The compression cycle of a rotary screw gas compression module is a continuous process from intake to discharge, which utilizes two intermeshing rotors with lobes and flutes. Rotation of the rotors draws gas into the rotor chamber through the inlet port and fills the flute volume created by the un-meshed rotors and the rotor housing. The flute volumes move axially and are closed and sealed internally after reaching a predetermined inlet cut-off

point. Fluid is injected into the closed compression chambers to seal, cool and lubricate. With continued rotation of the rotors, the rotor meshing reduces the volume of each compression chamber and increases the pressure. The pressure increases until the compression chamber communicates with the discharge port to allow the compressed gas/fluid mixture out of the compression module.

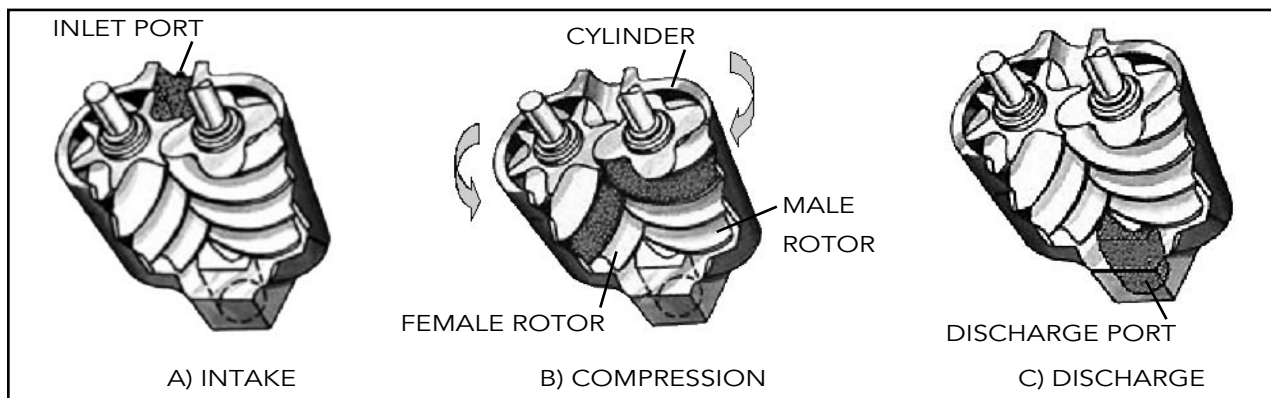

Compression Cycle

Volume Ratio (V_i)

QSG gas compression modules are available with two discrete internal (built-in) volume ratios (V_i) to match a wide range of applications. The selection of the proper V_i is critical to the performance of the compression module. If the actual pressure ratio is less than the theoretical pressure ratio determined by the internal volume ratio, the gas is compressed to a pressure greater than the application pressure. This condition, commonly referred to as over-compression, occurs when the discharge or outlet port opens

too late. If the actual pressure ratio is greater than the theoretical pressure ratio determined by the internal volume ratio, the discharge port opens too early, a condition referred to as under-compression. Both conditions decrease the efficiency of the compression module. In addition, over-compression results in bearing and shaft overloading.

Operational pressure ranges for both the low- and high-pressure gas compression modules are provided in Appendix A- Technical Data.

Capacity Control

QSG gas compression modules are available with lift valves for capacity control. Capacity control is achieved by controlling the effective length of the rotor compression cycle with four double-acting, pneumatic lift valves that open and close to return gas to the suction housing prior to compression. The lift valves can be actuated with internal gas pressure, eliminating an additional power requirement.

The lift valves can reduce the capacity by approximately 50% in steps, depending on the actual operating conditions. Each

valve, opened in sequence, will reduce the capacity by approximately 13%.

The lift valves should be actuated with pressurized gas. The actuation pressure should be close to the discharge pressure. The valve should be opened in the 1-2-3-4 sequence and closed in the 4-3-2-1 sequence.

A four-way, two-position valve is required to direct the actuation pressure to the lift valves and exhaust from the lift valves. The vented side of the valve must be directed to the dry-side of the inlet.

Compressor Performance Program (Q\$ize)

A compressor performance program (Q\$ize) is provided for use in selecting QSG gas compression modules. The program has been designed as a selection tool. Q\$ize provides the predicted

performance at the specified operating conditions. In addition, Q\$ize provides the lubrication requirements to assist the compressor packager with the fluid system design.

Section II - Description

Engine Adapters

SAE 0, 1, and 2 engine flywheel housing adapters are available for coupling to engine drives per Table 1.

Model	Rotor Diameter (mm)	SAE Engine Adapter
QSG 285	204	#2
QSG 350		
QSG 430		
QSG 580	255	#1
QSG 700		
QSG 850		
QSG 1170	321	#0
QSG 1460		
QSG 1750		

Table 1. SAE Engine Adapters

Fluid Flow

QSG gas compression modules distribute fluid internally to the rotors and bearings through machined passages. The internal passages have been designed to optimize the fluid distribution to the rotors and bearings based on differential fluid pressure and can accommodate a wide variety of operating conditions. The internal orifices are not adjustable in the QSG gas compression modules.

Since the QSG gas compression modules will operate in various conditions and fluid systems with different performance characteristics, each application must be evaluated using Q\$ize, Quincy Compressor's Performance Prediction

software, to ensure that there will be sufficient differential fluid pressure to distribute the fluid properly.

In applications where it is determined that there is insufficient differential fluid pressure, a positive displacement fluid pump will be required. QSG gas compression modules are available with a positive displacement fluid pump, driven from the male or female rotor discharge shaft, capable of covering a range of fluid flow requirements. The fluid pumps have speed limitations that are less than the speeds specified for the QSG gas compression modules. Please consult the factory for further details.

Compressor System

NOTICE!

All compressor system components must be constructed with materials compatible with the gas stream.

Suction Scrubber and Strainer

Inlet filters and scrubbers are required to eliminate liquid or solid carry-over to the compression module. A scrubber or some other liquid and particulate removal device must be installed immediately upstream

of each compression module. The suction scrubber must remove both free and entrained liquids, and filter particulate damaging to the compression module. The suction scrubber shall be equipped with a mesh-type mist elimination section to avoid liquid entrainment into the gas compression module.

A suction mesh strainer is also required. The suction mesh strainer guards against solid particulate, which can occasionally loosen from the piping wall.

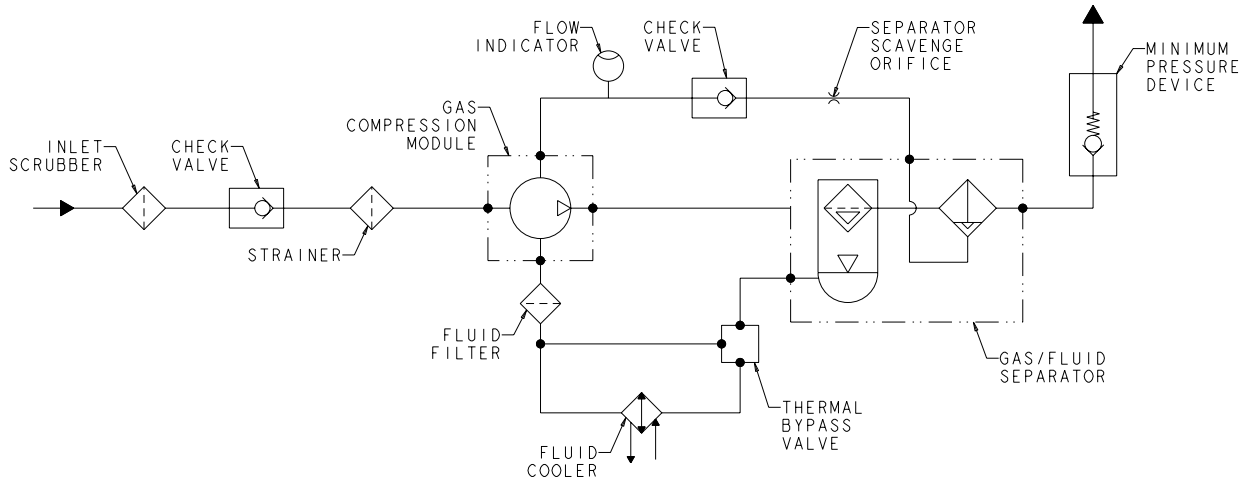

Typical Compressor System Diagram

Piping

Inlet Piping

On closed systems, the inlet piping must include the necessary filters and scrubbers to eliminate liquid or solid carry-over to the compression module. The design and construction of the inlet piping must not contain any low points between the scrubber and compression module piping to avoid potential liquid accumulation.

The inlet piping must be constructed with materials compatible with the gas stream and must be of sufficient size and design to minimize pressure drop, when sized for gas stream. The piping must include provisions to install other components such as gauges, valves, and temperature and pressure sensors as applicable. The piping and components must be adequately supported, allowing for thermal expansion, and must not distort the compression module housing, or affect compression module alignment when installed.

Discharge Piping

The discharge piping must be constructed with materials compatible with the gas stream and must be of sufficient size and design to minimize pressure drop, when sized for a mixed gas/fluid stream. The piping must include provisions to install other components such as gauges, valves, and temperature and pressure sensors as

applicable. The piping and components must be adequately supported, allowing for thermal expansion, and must not distort the compression module housing, or affect compression module alignment when installed.

Gas/Fluid Separator

A gas/fluid separator, complete with coalescing filter, is required on all fluid-flooded rotary screw compressors to maintain the pressurized, recirculating fluid system and to minimize fluid carryover in the process gas.

The packager must determine the gas/fluid separator vessel size required for each particular service. The gas/fluid separator must be designed to have adequate fluid coalescing filtration, complete with a coalescing filter fluid scavenge system. The scavenge line, containing a sight flow gauge, check valve and an orifice or an adjustable valve, must be connected to the compression module at the location specified on the applicable Installation Drawing.

Design of the gas/fluid separator must provide adequate fluid retention time and surface area to allow gas release from fluid. Separator retention times can range from one to two minutes depending on the separator design and compressor fluid used for the application.

Section II - Description

Fluid Cooler

A fluid cooler is required for all compressors to remove the heat of compression. The dewpoint of the process gas, operating conditions and the type of fluid combine to determine the maximum allowable fluid temperature into the compression module. The recommended injection fluid temperature is 150°F (65°C). The packager is responsible for properly sizing the fluid cooler considering the specified ambient and operating conditions.

Q-Size calculates the fluid flow rate based on the application input data: fluid injection and discharge temperatures and the fluid parameters.

Minimum Pressure Device

A minimum pressure device is required to maintain a minimum pressure in the gas/fluid separator. This device is particularly important when the possibility exists that the system pressure may not be sufficient to maintain pressure in the separator to achieve adequate gas/fluid separation.

Thermal Bypass Valve

The injection temperature of the fluid used to cool, seal and lubricate the compression module, is controlled by the thermal bypass valve, which allows part or all of the fluid flow to bypass the cooler, depending on the temperature of the fluid leaving the compression module.

Fluid Filter

The longevity of the compression module and the cleanliness of the injected fluid are interrelated. Specified micron and minimum efficiency ratings of the fluid filter protect the rotating components in the compression module from damage. Compressor full flow filtration shall equal or exceed a 12µm (micron) rating with 75 Beta ratio ($\beta_{12}=75$, 98.7% efficiency rating at removing particles 12 µm and larger).

Fluids

Quincy Compressor recommends QuinSyn-NG 100 compressor fluid for compressing natural gas. QuinSyn-NG 100 is an ISO 100 Group II hydro treated mineral oil (HTMO).

If QuinSyn-NG 100 is not selected, Quincy Compressor recommends utilizing an experienced lubricant consulting service to select the blended or synthetic fluid for the given application. These companies, provided the gas composition and operating conditions, have the capability of conducting proprietary flash gas and dilution calculations to determine proper lubrication and heat removal, as well as oxidation inhibition, rust and corrosion inhibition, and anti-wear properties.

A kinematic viscosity of 112 SUS (23 cSt) at the injection port is recommended.

- ◆ The minimum kinematic viscosity at operating conditions is 80 SUS (15 cSt). Compressor operation with fluid viscosity below 80 SUS (15 cSt) will result in inadequate compression module lubrication with bearing and sealing deterioration.
- ◆ The maximum kinematic viscosity at operating conditions is 142 SUS (30 cSt).

Frame

The frame design must provide adequate support under the compression module and other critical components. Generally, it is good practice to include gussets at support points.

The frame must have sufficient stiffness and strength to eliminate any bending or twisting of the compression module casing or misalignment between the driver (motor or engine) and compression module resulting from the dynamic or torque reaction forces generated by the rotating equipment. The entire frame must be able to withstand normal handling during transportation without permanently

distorting the frame or causing misalignment for the drive train when all components are mounted.

The frame design must prevent resonant vibration in the operating speed range.

Instrumentation and Controls

The compressor has critical operating parameters that require monitoring. In addition, some of the parameters require shutdown limits to protect the compression module from catastrophic failure. The table below identifies critical parameters along with the measurement location and the shutdown limit, where applicable.

PARAMETER	LOCATION	SHUTDOWN	GAUGE
DISCHARGE TEMPERATURE	DISCHARGE PIPE WITHIN FOUR (4) PIPE DIAMETERS OF DISCHARGE FLANGE	HIGH TEMPERATURE SHUTDOWN SET @ 10% ABOVE NORMAL OPERATING TEMPERATURE MAXIMUM = 230°F	TEMPERATURE GAUGE
DISCHARGE PRESSURE	DISCHARGE PIPE WITHIN FOUR (4) PIPE DIAMETERS OF DISCHARGE FLANGE	HIGH PRESSURE SHUTDOWN	PRESSURE GAUGE
FLUID LEVEL	GAS/OIL SEPARATOR	LOW FLUID LEVEL SHUTDOWN	FLUID LEVEL SIGHT GAUGE
LIQUID LEVEL	INLET GAS SCRUBBER	HIGH LIQUID LEVEL SHUTDOWN	LIQUID LEVEL SIGHT GAUGE
SUCTION TEMPERATURE	SUCTION LINE DOWNSTREAM OF INLET SCRUBBER AND STRAINER		TEMPERATURE GAUGE
SUCTION PRESSURE	SUCTION LINE DOWNSTREAM OF INLET SCRUBBER AND STRAINER		PRESSURE GAUGE
FLUID SUPPLY TEMPERATURE	COMPRESSOR FLUID SUPPLY CONNECTION	HIGH TEMPERATURE SHUTDOWN SET @ 10% ABOVE NORMAL OPERATING TEMPERATURE MAXIMUM = 170°F	TEMPERATURE GAUGE
FLUID SUPPLY PRESSURE	COMPRESSOR FLUID SUPPLY CONNECTION		PRESSURE GAUGE
COALESCING SCAVENGE FLUID FLOW	SCAVENGE LINE BETWEEN GAS/FLUID SEPARATOR AND COMPRESSION MODULE		FLOW INDICATOR

Section III - Installation

- Receiving
- Freight Damage
- Location
- Electrical Supply Requirements
- Mounting
- System Components

Receiving

Immediately upon receipt of compressor equipment and prior to completely uncrating, the following steps should be taken:

- 1) Inspect compressor equipment for damage that may have occurred during shipment. If any damage is found, demand an inspection from the carrier. Ask the carrier how to file a claim for shipping damages. (Refer to Freight Damage instructions in this section for complete details.) Shipping damage is not covered by Quincy Compressor warranty.
- 2) Insure that adequate lifting equipment is available for moving the compressor equipment.



CAUTION!

Improper lifting may result in component or system damage, or personal injury. Follow good shop practices and safety procedures when moving the unit.

- 3) Read the compression module nameplate to verify the model and size ordered.
- 4) Read and understand the safety precautions contained within this manual. The successful and efficient operation of compressor equipment depends largely upon the amount of care taken to install and maintain the equipment.

Freight Damage

It is extremely important to examine every carton and crate as soon as you receive it. If there is any obvious damage to the shipping container, have the delivering carrier sign the freight bill, noting the apparent damage, and request a damage report.

NOTICE!

If concealed damage is discovered at a later date, the carrier must be notified within 15 days of initial receipt of freight. Concealed shipping damage is not covered by Quincy Compressor Warranty.

Contact the carrier as soon as possible, giving them an opportunity to inspect the shipment at the premises where the delivery was made. Do not move the damaged freight from the premises where the original delivery was made.

Retain all containers and packing for inspection by the carrier.

A claim form (form # 3208 - Standard Form for Presentation of Loss and Damage Claims) can be requested from the carrier.

Your claim will need to be substantiated with the following documents:

- ◆ Form #3208
- ◆ Original bill of lading
- ◆ Original paid freight bill
- ◆ Original invoice or certified copy
- ◆ Other particulars obtainable in proof of loss or damage (photos, damage inspection, etc.)

The proper description and classification of this product in the National Motor Freight Classification, reads as follows:

“Compressors, air, or airends: with or without air tanks, hose or nozzles, mounted or not mounted.”

We suggest that these instructions be circulated to your shipping and receiving personnel.

Section III - Installation

Location

Inspection and maintenance checks are required daily, therefore, sufficient space needs to be provided around the compressor for safe and proper inspection, cleaning, and maintenance.



WARNING!

Never assume a compressor is safe to work on just because it is not operating. It could restart at any time. Follow all safety precautions outlined in Section V - Stopping For Maintenance.

Do not allow hot air from additional equipment to blow towards the compressor. The compressor should be operated in temperatures under 104°F.

Do not operate the compressor in ambient temperatures lower than -15°F.



WARNING!

Under no circumstances should a compressor be installed in an area exposed to a toxic, volatile or corrosive atmosphere, nor should toxic, volatile or corrosive agents be stored near the compressor.

Noise

Noise is a potential health hazard that must be considered. There are federal and local laws governing acceptable noise levels. Check with local officials for specifications.

Excessive noise can be effectively reduced through various methods. Total enclosures, intake silencers, baffle walls, relocating or isolating the compressor can reduce noise levels. Care must be taken when constructing total enclosures or baffle walls. If not properly constructed or positioned, they could contribute to unacceptable noise levels or overheating. Consult your local Quincy Authorized Gas Packager if assistance is required.



CAUTION!

Unusual noise or vibration indicates a problem. Do not operate the compressor until the source has been identified and corrected.

Mounting

Proper mounting of Quincy natural gas compression modules is critical to the safe operation and longevity of the equipment. The compressor must be mounted on a skid or base. The support points should be flat and parallel to the compressor

mounting feet, which must be supported in a fashion that provides both vertical and lateral support to ensure proper alignment. The packager must ensure the natural frequency of the mounted base is not excited by the compressor.

System Components

Natural gas compressors are used for a wide range of applications, each with their own specific requirements for supportive and protective system components. For this reason Quincy Compressor includes minimal information regarding the vast array of available components.

Safety and efficiency are the primary concerns when selecting components for compressed natural gas systems. All components used on a natural gas compressor must be designed to operate safely (at a minimum) in a Class 1, Division 2, Group D environment. Products of inferior quality can not only hinder performance of the unit, but could cause system failures that result in bodily harm or even death. Select only top quality components for your system. Call your local Quincy Authorized Gas Packager for quality parts and professional advice.

Guards

All mechanical action or motion is hazardous in varying degrees and needs to be guarded. Guards should be designed to achieve the required degree of protection and still allow full air flow for cooling. Guards shall be in compliance with OSHA safety and health standards 29 CFR 1910.219 in OSHA manual 2206 and any state or local codes.



WARNING!

Guards must be fastened in place before starting the compressor and never removed before cutting off and locking out the main power supply (refer to Section V - Stopping for Maintenance).

Pressure Relief Valves

Pressure relief valves aid in preventing system failures by relieving system pressure when compressed natural gas reaches a determined level. They are available in various pressure settings to accommodate a range of applications. Pressure relief valves are preset by the manufacturer and under no circumstances should the setting be changed by anyone other than the manufacturer.



DANGER!

Pressure relief valves must be provided to protect compressed natural gas systems in accordance with ASME B19 safety standards. Failure to provide properly sized pressure relief valves may cause property damage, severe personal injury or even death.

Section IV - Operating Procedures

- Prior to Starting
- Starting the Compressor
- Stopping the Compressor

Prior to Starting



CAUTION!

This instruction manual, as well as any instructions supplied by manufacturers of supporting equipment, should be read and understood prior to starting the compressor. If there are any questions regarding any part of the instructions, please call your local Quincy Authorized Gas Packager, or the Quincy Compressor factory.

Before starting the compressor, review Sections II and III of this manual. Be certain that all installation requirements have been met and that the purpose and use of the machine are thoroughly understood.



WARNING!

QSG gas compression modules are shipped from the factory without lubricating fluid. An appropriate lubricating fluid must be added to the compressor package prior to start-up to prevent damaging the QSG gas compression module.



WARNING!

Failure to complete this checklist may result in mechanical failure, property damage, serious injury or even death.

The following steps should be performed prior to connecting the unit to a power source. If any condition of the checklist is not satisfied, make the necessary adjustments or corrections before starting the compressor.

- ◆ Remove all loose items and tools from around the compressor.
- ◆ Check the fluid level.



NOTICE!

This manual covers only the gas compression module. Reference the compressor package specifications for fluid level guidelines.

- ◆ If applicable, check motor pulley and compression module sheaves for alignment and tightness on shaft. (Refer to Section V - Pulley/Sheave Alignment & Belt Tension.)
- ◆ Manually rotate the compression module sheave several rotations to be sure there are no mechanical interferences.
- ◆ Check inlet piping installation.
- ◆ Check all pressure connections for tightness.
- ◆ Make sure all pressure relief valves are correctly installed.
- ◆ Be sure all guards are in place and securely mounted.
- ◆ Check fuses, circuit breakers, and thermal overloads for proper size.
- ◆ Open all manual shutoff valves at and beyond the compression module discharge.
- ◆ After all the above conditions have been satisfied, the unit can be connected to the proper power source.



WARNING!

Operating the compression module with incorrect rotation will result in extreme damage to the compression module and warranty coverage will be voided.

Starting the Compressor

With the pre-starting checklist completed and satisfied, start the compressor. Watch and listen for excessive vibration and strange noises. If either exist, stop the compressor. Refer to Section VI - Troubleshooting for help in determining the cause of such problems.

Observe compressor operation closely for the first hour of operation and then frequently for the next seven hours. After the first eight hours, monitor the compressor at least once every eight hours. If any abnormal conditions are witnessed, stop the compressor and correct the problem. After two days of operation check belt tension (if necessary), fluid level, and inspect the system for leaks.

Daily Starting Checklist

- ◆ Check fluid level.
- ◆ Drain liquid from the discharge system.
- ◆ Jog the starter switch to check compression module rotation. Proper rotation is clockwise (as viewed from the power-input end). The power-input end of the compression module is marked with an arrow noting the proper rotation.
- ◆ Start the compressor per factory instructions.
- ◆ Check fluid supply pressure.
- ◆ Check system pressure.
- ◆ Check cooling fan.
- ◆ Check all pressure relief valves for proper operation.
- ◆ Check control system for proper operation.

Stopping the Compressor

Normal, Emergency or Service Operation

Disconnect and lockout the main power source. Display a sign in clear view at the main power switch stating that the compressor is shut down. (Lockout/Tagout per OSHA regulation 1910.147: The Control of Hazardous Energy Source.)

Isolate the compressor from the compressed natural gas supply by closing a manual shutoff valve upstream and downstream from the compressor. Display a sign in clear view at the shutoff valve stating that the compressor is shut down.

Section V - Servicing

- Preparing for Maintenance or Service
- Maintenance Schedule
- Mechanical Shaft Seal Installation
- Pulley/Sheave Alignment & Belt Tension

Preparing for Maintenance or Service



WARNING!

Never assume a compressor is safe to work on just because it is not operating. It could restart at any time.

It is vitally important to remember that internal pressure can exist inside a natural gas compressor whenever it is linked to a pressurized natural gas supply. Do not attempt to remove the fluid pump, fluid filter, or any other parts of the compressor until the following instructions have been read, understood and satisfied.

The following procedures) should be followed when stopping the compressor for maintenance or service:

- ◆ Disconnect and lockout the main power source. Display a sign in clear view at the main power switch stating that the compressor is being serviced (Lockout/Tagout per OSHA regulation 1910.147: The Control of Hazardous Energy Source).

- ◆ Isolate the compressor from the compressed natural gas supply by closing a manual shutoff valve upstream and downstream from the compressor. Display a sign in clear view at the shutoff valve stating that the compressor is being serviced.
- ◆ Open a pressure relief valve within the pressurized system to allow the system to be completely depressurized.



WARNING!

NEVER remove a plug to relieve the pressure!

- ◆ Open all manual drain valves within the area to be serviced.
- ◆ Wait for the unit to cool before starting to service. (Temperatures of 125°F can burn skin.)
- ◆ Allow ample time for the work area to be ventilated of all natural gas.

Maintenance Schedule

To assure maximum performance and service life of your compressor, a routine maintenance schedule should be developed. A sample schedule has been included here to help you to develop a maintenance schedule designed for your particular application.

The following schedule is intended to be used as a guideline only. Depending on the specific operating conditions of your compressor, maintenance requirements

may vary. Time frames may need to be shortened in harsher environments.

At the back of this instruction manual you will find a Maintenance Record form. Make copies of this page and retain the master to make more copies as needed. Keep a copy of all maintenance records, copies of the blank record form and this instruction manual readily available near the compressor.

EVERY 8 HOURS (DAILY)	CHECK FLUID LEVEL AND FLUID CONDITION. (DISCOLORATION OR A HIGH FLUID LEVEL READING MAY INDICATE THE PRESENCE OF CONDENSED LIQUIDS.) IF FLUID IS CONTAMINATED, DRAIN AND REPLACE.
	DRAIN DROP LEGS AND TRAPS IN NATURAL GAS DISTRIBUTION SYSTEM.
	GIVE COMPRESSOR AN OVERALL VISUAL INSPECTION AND BE SURE SAFETY GUARDS ARE IN PLACE.
	CHECK FOR ANY UNUSUAL NOISE OR VIBRATION.
	CHECK FOR FLUID LEAKS.
EVERY 40 HOURS (WEEKLY)	MANUALLY OPERATE THE PRESSURE RELIEF VALVES TO BE CERTAIN THEY ARE WORKING.
	CLEAN THE COOLING SURFACES OF THE INTERCOOLER AND COMPRESSOR.
	CHECK THE COMPRESSOR FOR NATURAL GAS LEAKS.
	CHECK THE COMPRESSED NATURAL GAS DISTRIBUTION SYSTEM FOR LEAKS.
	INSPECT FLUID FOR CONTAMINATION & CHANGE IF NECESSARY.
EVERY 700 HOURS (MONTHLY)	CHECK BELT TENSION (IF APPLICABLE).
	TORQUE PULLEY CLAMP SCREWS OR JAM NUT.
EVERY 4000 HOURS (EVERY 6 MONTHS)	REPLACE COMPRESSOR FLUID AND FLUID FILTER. (THIS SERVICE MAY NEED TO BE PERFORMED MORE FREQUENTLY IF RECOMMENDED BY THE FILTER MANUFACTURER OR FLUID CONSULTANT.)

 **NOTICE!**

Failure to follow these maintenance and service recommendations may adversely affect your warranty. Maintain accurate and complete maintenance records to ensure warranty compliance.

Section V - Servicing

Mechanical Shaft Seal Installation

Quincy Compressor QSG gas compression modules are equipped with mechanical seals, which are delicate and highly precision parts requiring care in handling and installation. The following steps must be followed during the installation/replacement of the seal to ensure proper operation of the seal. Every effort should be made to perform the work in a clean environment.

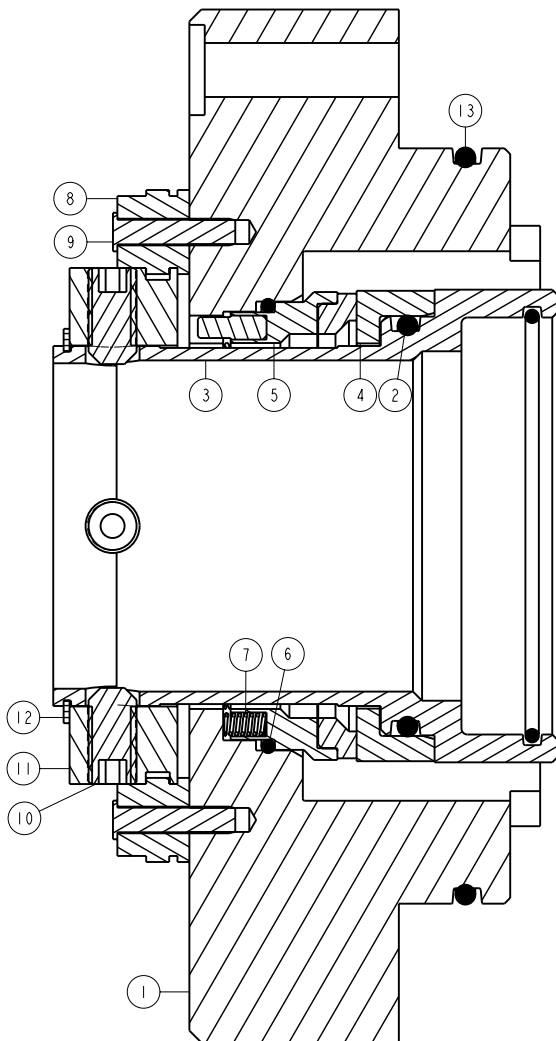

1. Locate all of the required parts for the assembly. Deburr the metal components as required. Blow out all passages and wipe down when finished.
 - a. Inspect seal adapter (item 1):
 - i. Seal bore finish. Discard if nicks or deep scratches exist in the area where the o-ring seals.
 - ii. Seal bore chamfer. Remove nicks and sharp edges from chamfer. Add chamfer if non-existent.
 - b. Inspect o-rings for flat spots, nicks, or cuts. Scrap if any are found.
2. Apply the lubricant included in the kit to the o-ring (item 2) and install on the outer diameter of the sleeve (item 3).
3. Place the rotary face (item 4) on the sleeve (item 3) with the lapped face on top. **DO NOT TOUCH OR DROP THE LAPPED FACE AT ANY TIME.** In the event of contact with the face, spray the surface with glass cleaning solution and wipe with a lint-free cloth to remove any contaminants.
4. Inspect the lapped face of the carrier (item 5) and clean if necessary as outlined in step 3. Place the carrier (item 5) on top of the rotary face (item 4), seating it squarely against the o-ring (item 2). Use the carrier to press the rotary face down until it snaps into place. If necessary, place the seal adapter (item 1) on the carrier, aligning it with the pins, and use it to press down on the carrier for extra leverage. **NEXT, REMOVE THE CARRIER AND SPRAY A LIGHT MIST OF MOBIL VELOCITE OIL #6 OR EQUIVALENT.** Replace the carrier on top of the rotary face and spin it on the carrier to seat it properly.

5. Using the lubricant in the kit, lubricate o-ring (item 6) and place it in the first step in the carrier. This must be done before installing the springs (item 7).
6. Insert the springs (item 7) into the holes in the carrier (item 5).
7. Install the alignment clips (item 8) by placing the seal adapter on a flat, clean surface. Insert the pin (item 9) through each clip, with the head of the pin at the smaller end of the clip. Using a small hammer, tap the clip pins into the holes provided until the bottom of the clip is in contact with the top of the clip. **DO NOT DAMAGE THE CLIPS BY DRIVING THE PIN IN TOO FAR.** There should be some resistance when you rotate the clip, but not too tight.
8. Hold the seal adapter (item 1) over the prepared sleeve assembly and align the holes in the seal adapter with the anti-rotation pins in the carrier. Slowly lower the seal adapter down onto the carrier until you see a pin through each slot. If adjustment is required to align properly, lift the seal adapter and rotate it. **DO NOT ROTATE THE SEAL ADAPTER ON THE CARRIER O-RING.**
9. When you have the seal adapter properly positioned, press it all the way down. This will push the pins through the holes and engage the o-ring. When you release pressure on the seal adapter, the springs should offer some rebound. Press the seal adapter down a few times and release it to ensure that the face is straight and the pins are sliding freely through the holes.
10. Install the set screws (item 10) in the collar (item 11), but do not engage them past the inner diameter of the collar. Place the collar on the sleeve (item 3) with the step facing down. The alignment clips must be rotated to the side to install the collar.
11. Install the snap ring (item 12) to retain the collar. Rotate the collar and align the set screw holes with the holes in the sleeve. Engage the set screws just enough to prevent the drive collar from rotating in the sleeve, but not far enough to scratch the rotor shaft during installation.
12. Insert the four (4) shims in the seal kit between the collar and the seal adapter by lifting on the collar and pressing down on the seal adapter. This will compress the springs at the proper setting. Next, center the collar by rotating each of the clips so that they engage the collar. Use pliers as necessary.
13. Using the lubricant in the kit, lubricate the last two o-rings (item 6) and (item 13). Install o-ring (item 6) inside the sleeve and o-ring (item 13) on the outer diameter of the seal adapter.
NOTE: The I.D. o-ring (item 6) needs to be "stretched" to fit securely in the groove. After applying lubricant, gently stretch the o-ring to the desired size.
14. Place the spacer over the rotor shaft and lower into place. It does not matter which way you install it.
15. Place the seal adapter assembly over the rotor shaft and lower into place. Install proper bolts and slowly run them down with a speed handle, taking care not to cut the o-ring. Torque the bolts to specification.

Section V - Servicing

16. Ensure the gap between the rotor shaft and the seal collar is equal top/bottom and side/side using a feeler gauge or shim stock. Adjust the retaining allen screws as required to obtain the correct alignment. This will reduce the possibility of leaks and excessive seal wear.
17. Rotate the collar if necessary so that the pins do not block access to the set screws. Place Loctite 242 on the set screws and tighten with the supplied allen wrench, taking care to keep the shaft centered in the collar.
18. The collar is now locked into place on the rotor shaft. Use the pliers to rotate each of the pins 90 degrees so that they do not contact the collar and remove the shims. This completes the installation of the mechanical seal.
19. The run out of the seal face must be LESS THAN 0.0015 inches. To determine the run out place the magnetic holder and dial indicator on the airend with the dial indicator ball resting unobstructed on the top lip of the seal carrier. Use the keyway as your zero point and record the dial reading of the indicator while rotating the rotor shaft to 0° (key way), 90°, 180° and 270°. Adjust (loosen or tighten) the collar set screws until the total dial movement is less than 0.0015 inches.

Compressor Drive

QSG gas compression modules can be driven by coupling directly to an engine drive or an electric motor or they can be driven by a belt system.

When an engine or an electric motor is the driver the compressor must be driven through a flexible coupling to absorb torsional vibrations of the driver by dissipating energy into the flexible element(s). The selected element must dissipate the required vibration energy without overheating. The packager should follow the coupling manufacturer's requirements regarding coupling alignment.

When a belt system is used, the correct drive pulley diameter must be selected to obtain proper pressure and natural gas delivery without overloading the motor, or operating the compressor above or below

the designed speed range. Belt drive power limits are provided in Appendix A.

It is equally important to properly align the compressor and drive pulley, and maintain the correct drive belt tension. Improper pulley alignment and belt tension are causes for motor overloading, excessive vibration, and premature belt and/or bearing failure.

Quincy Compressors's liability is limited to the QSG gas compression module as supplied by Quincy Compressor, and is limited to defects in material and workmanship. Any modifications of system components related to the operation of the gas compression module such as (but not limited to) the suction and discharge connections and drive arrangements are the responsibility of the owner/operator.

Section VI - Troubleshooting

Problem:	Probable Cause:
LOW DISCHARGE PRESSURE & NATURAL GAS DELIVERY:	RESTRICTED INLET LEAKS IN THE NATURAL GAS SYSTEM AT FITTINGS, CONNECTIONS, ETC. PRESSURE SWITCH DEFECTIVE OR SET WRONG DRIVE BELT SLIPPING INCORRECT SPEED DRAIN VALVE OPEN DEFECTIVE PRESSURE GAUGE PRESSURE RELIEF VALVE LEAKING
LOW NATURAL GAS DELIVERY:	LOW INLET PRESSURE EXCESSIVE DISCHARGE PRESSURE
EXCESSIVE VIBRATION:	LOOSE PULLEY/SHEAVE MOTOR, ENGINE OR DRIVE COUPLING OUT OF BALANCE COMPRESSOR, MOTOR OR ENGINE NOT SECURED TIGHTLY, OR TIGHTENED INTO A BIND FOUNDATION OR FRAME INADEQUATE PIPING INADEQUATELY SUPPORTED OR TIGHTENED INTO A BIND EXCESSIVE DISCHARGE PRESSURE COMPRESSOR FEET MAY NEED TO BE LEVELED WITH SHIMS COMPONENTS OR GAS VOLUME NATURAL FREQUENCY IS EQUAL TO OR NEAR THE COMPRESSOR PRIME ROTATIONAL FREQUENCY
EXCESSIVE DRIVE BELT WEAR (IF APPLICABLE):	PULLEY/SHEAVE OUT OF ALIGNMENT BELT TOO LOOSE OR TOO TIGHT BELT SLIPPING PULLEY/SHEAVE WOBBLING PULLEY/SHEAVE GROOVE DAMAGED OR ROUGH INCORRECT BELTS
LOW FLUID PRESSURE:	FLUID PUMP DIRECTION REVERSED FLUID SUMP STRAINER PLUGGED EXCESSIVE LEAKAGE AT SHAFT SEALS LOW FLUID LEVEL DEFECTIVE FLUID PRESSURE GAUGE PLUGGED FLUID FILTER
COMPRESSOR OVERHEATING	CLOGGED INTAKE SYSTEM CLOGGED FLUID COOLER, INTERNALLY OR EXTERNALLY INADEQUATE VENTILATION, OR RECIRCULATION OF HOT AIR PULLEY/SHEAVE ROTATION WRONG INCORRECT SPEED INADEQUATE FLUID COOLING SYSTEM (COOLERS, FAN, FAN MOTOR, ETC.) OR COMPRESSOR INCORRECTLY SIZED

Section VI - Troubleshooting

Problem:	Probable Cause:
HIGH DISCHARGE TEMPERATURE	DISCHARGE PRESSURE TOO HIGH INADEQUATE VENTILATION OR HOT AIR RECIRCULATING COOLING SURFACES OF FLUID COOLER EXCESSIVELY DIRTY INTERNAL SURFACE OF HEAT EXCHANGER FOULED AMBIENT TEMPERATURE TOO HIGH
EXCESSIVE FLUID CONSUMPTION	COOLING SYSTEM OR COMPRESSOR INCORRECTLY SIZED COMPRESSOR RUNNING TOO HOT (HIGH DISCHARGE TEMPERATURE) FLUID VISCOSITY WRONG FOR THE APPLICATION LEAKING FLUID SEAL INFERIOR GRADE OF FLUID GAS/FLUID SEPARATOR ELEMENT NEEDS TO BE CHANGED CLOGGED SCAVENGE LINE
EXCESSIVE CURRENT DRAW (ELECTRICAL DRIVE) (TO DETERMINE MAXIMUM AMPERAGE ALLOWED, MULTIPLY THE FLA ON THE MOTOR NAMEPLATE BY THE SERVICE FACTOR.) CAUTION! MOTOR SURFACE TEMPERATURE NORMALLY EXCEEDS 170° F.	LOW VOLTAGE (MUST BE WITHIN 10% OF NAMEPLATE VOLTAGE) LOOSE ELECTRICAL CONNECTION WIRE SIZE TOO SMALL INCORRECT FLUID SUCTION PRESSURE TOO HIGH DISCHARGE PRESSURE TOO HIGH AFTERCOOLER PLUGGING BEARINGS TIGHT OR SEIZING MOTOR SIZED INCORRECTLY MOTOR DEFECTIVE DRIVE BELTS TOO TIGHT (BELT DRIVE)
FAILURE TO START (ELECTRICAL DRIVE)	POWER NOT ON BLOWN CIRCUIT FUSE THERMAL OVERLOAD FUSES TRIPPED LOW VOLTAGE FAULTY START SWITCH POWER FAILURE PRESSURE SWITCH INCORRECTLY ADJUSTED OR FAULTY LOOSE OR BROKEN WIRE MOTOR DEFECTIVE COMPRESSOR SEIZED
MOTOR STALLS (ELECTRICAL DRIVE)	MOTOR OVERLOADED (REFER TO EXCESSIVE CURRENT DRAW)

Appendix A - Technical Data

High Pressure

MODEL NAME	QSG-225	QSG-285	QSG-350	QSG-430	QSG-580
MALE ROTOR DIAMETER (MM)	127.5	204	204	204	255
MALE ROTOR LOBES	4	4	4	4	4
FEMALE ROTOR LOBES	6	6	6	6	6
L/D RATIO	1.70	1.02	1.23	1.55	1.12
VOLUME RATIO, VI	4.6	4.5	4.5	4.5	4.5
PRESSURE RATIO - MAX	10	10	10	10	10
MALE ROTOR OPERATING SPEED (RPM)	1200-6800	1000-4800	1000-4800	1000-4800	1000-3750
FLOW CAPACITY (CFM)	70-330	140-570	170-690	210-870	300-940
(MSCFD)	100-480	200-820	240-990	300-1250	430-1350
RATED POWER (BHP)	75	110	140	170	200
BELT DRIVE POWER (BHP)	50	70	70	70	130
TORQUE - MAX (IN LBS)	2300	3400	3400	3400	8200
SUCTION PRESSURE (PSIA)	12-35	12-29	12-29	12-29	12-29
DISCHARGE PRESSURE (PSIG)	75-210	75-165	75-165	75-165	75-165
DISCHARGE TEMPERATURE - MAX (°F)	220	220	220	220	220

MODEL NAME	QSG-700	QSG-850	QSG-1170	QSG-1460	QSG-1750
MALE ROTOR DIAMETER (MM)	255	255	321.3	321.3	321.3
MALE ROTOR LOBES	4	4	4	4	4
FEMALE ROTOR LOBES	6	6	6	6	6
L/D RATIO	1.34	1.70	1.14	1.42	1.70
VOLUME RATIO, VI	4.5	4.5	4.7	4.7	4.7
PRESSURE RATIO - MAX	10	10	10	10	10
MALE ROTOR OPERATING SPEED (RPM)	1000-3750	1000-3750	900-3600	900-3600	900-3600
FLOW CAPACITY (CFM)	360-1140	440-1400	540-1820	670-2240	800-2680
(MSCFD)	520-1640	630-2020	780-2620	960-3230	1150-3860
RATED POWER (BHP)	240	380	480	540	610
BELT DRIVE POWER (BHP)	130	130	N/A	N/A	N/A
TORQUE - MAX (IN LBS)	8200	8200	15000	15000	15000
SUCTION PRESSURE (PSIA)	12-29	12-29	12-27	12-27	12-27
DISCHARGE PRESSURE (PSIG)	75-165	75-165	75-165	75-165	75-165
DISCHARGE TEMPERATURE - MAX (°F)	220	220	220	220	220

Appendix A - Technical Data

Low Pressure

MODEL NAME	QSG-225LP	QSG-285LP	QSG-430LP
MALE ROTOR DIAMETER (MM)	127.5	204	204
MALE ROTOR LOBES	4	4	4
FEMALE ROTOR LOBES	6	6	6
L/D RATIO	1.70	1.02	1.55
VOLUME RATIO, V_1	1.9	2.5	2.5
PRESSURE RATIO - MAX	4.5	4.5	4.5
MALE ROTOR OPERATING SPEED (RPM)	1200-6800	1000-4800	1000-4800
FLOW CAPACITY (CFM)	70 -330	140-570	210-870
(Mscfd)	100-480	200-820	300-1250
RATED POWER (BHP)	75	110	170
BELT DRIVE POWER (BHP)	50	70	70
TORQUE - MAX (IN LBS)	2300	3400	3400
SUCTION PRESSURE (PSIA)	12-54	12-39	12-39
DISCHARGE PRESSURE (PSIG)	15-100	15-100	15-100
DISCHARGE TEMPERATURE - MAX (F)	220	220	220

MODEL NAME	QSG-580LP	QSG-850LP	QSG-1750LP
MALE ROTOR DIAMETER (MM)	255	255	321.3
MALE ROTOR LOBES	4	4	4
FEMALE ROTOR LOBES	6	6	6
L/D RATIO	1.12	1.70	1.70
VOLUME RATIO, V_1	1.9	1.9	1.9
PRESSURE RATIO - MAX	4.5	4.5	4.5
MALE ROTOR OPERATING SPEED (RPM)	1000-3750	1000-3750	900-3600
FLOW CAPACITY (CFM)	300-940	440-1400	800-2680
(Mscfd)	430-1350	630-2020	1150-3860
RATED POWER (BHP)	200	380	610
BELT DRIVE POWER (BHP)	130	130	N/A
TORQUE - MAX (IN LBS)	8200	8200	15000
SUCTION PRESSURE (PSIA)	12-54	12-54	12-54
DISCHARGE PRESSURE (PSIG)	15-100	15-100	15-100
DISCHARGE TEMPERATURE - MAX (F)	220	220	220

Appendix B - Maintenance Record

Use the form on the following page to develop a routine maintenance schedule and record of performed maintenance.

At each service interval, enter the initials of the person who performed the maintenance and the date.

Enter additional maintenance procedures in the spaces provided as needed per your application.

Reference the maintenance schedule on page 19 for recommended service intervals.

Equipment operating under humid or dirty conditions may require shorter intervals between scheduled maintenance.

This instruction manual, as well as any instructions supplied by manufacturers of supporting equipment, should be read and understood prior to performing maintenance.



NOTICE!

Make your entries on a copy of the form. Retain the original form to make more copies in the future.

Appendix B - Maintenance Record

EQUIPMENT ID: _____ LOCATION: _____ ORIGINAL START-UP DATE: _____
MAINTENANCE RECORD (DATE) FROM: _____ TO: _____

MAINTENANCE PROCEDURE	INITIALS	DATE	INITIALS	DATE	INITIALS	DATE
MANUALLY TEST PRESSURE RELIEF VALVES						
CLEAN FLUID COOLER & AFTERCOOLER SURFACES						
CHECK DISTRIBUTION SYSTEM FOR LEAKS						
CHECK FOR CONTAMINATED FLUID						
CHECK FOR COMPRESSOR/VACUUM LEAKS						
CHECK BELT TENSION (IF APPLICABLE)						
TORQUE SHEAVE FASTENERS (IF APPLICABLE)						
CHANGE FLUID & FILTER						
REPLACE GAS/FLUID SEPARATOR ELEMENT						

STANDARD TERMS AND CONDITIONS

QUINCY COMPRESSOR AND ORTMAN FLUID POWER DIVISIONS

LEGAL EFFECT: Except as expressly otherwise agreed to in writing by an authorized representative of Seller, the following terms and conditions shall apply to and form a part of this order and any additional and/or different terms of Buyer's purchase order or other form of acceptance are rejected in advance and shall not become a part of this order.

The rights of Buyer hereunder shall be neither assignable nor transferable except with the written consent of Seller.

This order may not be canceled or altered except with the written consent of Seller and upon terms which will indemnify Seller against all loss occasioned thereby. All additional costs incurred by Seller due to changes in design or specifications, modification of this order or revision of product must be paid for by Buyer.

In addition to the rights and remedies conferred upon Seller by this order, Seller shall have all rights and remedies conferred at law and in equity and shall not be required to proceed with the performance of this order if Buyer is in default in the performance of such order or of any other contract or order with seller.

TERMS OF PAYMENT: Unless otherwise specified in the order acknowledgment, the terms of payment shall be net cash within thirty (30) days after shipment. These terms shall apply to partial as well as complete shipments. If any proceeding be initiated by or against Buyer under any bankruptcy or insolvency law, or in the judgment of Seller the financial condition of Buyer, at the time the equipment is ready for shipment, does not justify the terms of payment specified, Seller reserves the right to require full payment in cash prior to making shipment. If such payment is not received within fifteen (15) days after notification of readiness for shipment, Seller may cancel the order as to any unshipped item and require payment of its reasonable cancellation charges.

If Buyer delays shipment, payments based on date of shipment shall become due as of the date when ready for shipment. If Buyer delays completion of manufacture, Seller may elect to require payment according to percentage of completion. Equipment held for Buyer shall be at Buyer's risk and storage charges may be applied at the discretion of Seller.

Accounts past due shall bear interest at the highest rate lawful to contract for but if there is no limit set by law, such interest shall be eighteen percent (18%). Buyer shall pay all cost and expenses, including reasonable attorney's fees, incurred in collecting the same, and no claim, except claims within Seller's warranty of material or workmanship, as stated below, will be recognized unless delivered in writing to Seller within thirty (30) days after date of shipment.

TAXES: All prices exclude present and future sales, use, occupation, license, excise, and other taxes in respect of manufacture, sales or delivery, all of which shall be paid by Buyer unless included in the purchase price at the proper rate or a proper exemption certificate is furnished.

ACCEPTANCE: All offers to purchase, quotations and contracts of sales are subject to final acceptance by an authorized representative at Seller's plant.

DELIVERY: Except as otherwise specified in this quotation, delivery will be F. O. B. point of shipment. In the absence of exact shipping instruction, Seller will use its discretion regarding best means of insured shipment. No liability will be accepted by Seller for so doing. All transportation charges are at Buyer's expense. Time of delivery is an estimate only and is based upon the receipt of all information and necessary approvals. The shipping schedule shall not be construed to limit seller in making commitments for materials or in fabricating articles under this order in accordance with Seller's normal and reasonable production schedules.

Seller shall in no event be liable for delays caused by fires, acts of God, strikes, labor difficulties, acts of governmental or military authorities, delays in transportation or procuring materials, or causes of any kind beyond Seller's control. No provision for liquidated damages for any cause shall apply under this order. Buyer shall accept delivery within thirty (30) days after receipt of notification of readiness for shipment. Claims for shortages will be deemed to have been waived if not made in writing within ten (10) days after the receipt of the material in respect of which any such shortage is claimed. Seller is not responsible for loss or damage in transit after having received "In Good Order" receipt from the carrier. All claims for loss or damage in transit should be made to the carrier.

STANDARD TERMS AND CONDITIONS

QUINCY COMPRESSOR AND ORTMAN FLUID POWER DIVISIONS

TITLE & LIEN RIGHTS: The equipment shall remain personal property, regardless of how affixed to any realty or structure. Until the price (including any notes given therefore) of the equipment has been fully paid in cash, Seller shall, in the event of Buyer's default, have the right to repossess such equipment.

PATENT INFRINGEMENT: If properly notified and given an opportunity to do so with friendly assistance, Seller will defend Buyer and the ultimate user of the equipment from any actual or alleged infringement of any published United States patent by the equipment or any part thereof furnished pursuant hereto (other than parts of special design, construction, or manufacture specified by and originating with Buyer), and will pay all damages and costs awarded by competent court in any suit thus defended or of which it may have had notice and opportunity to defend as aforesaid.

STANDARD WARRANTY: Seller warrants that products of its own manufacture will be free from defects in workmanship and materials under normal use and service for the period specified in the product instruction manual. Warranty for service parts will be ninety (90) days from date of factory shipment. Electric Motors, gasoline and diesel engines, electrical apparatus and all other accessories, components and parts not manufactured by Seller are warranted only to the extent of the original manufacturer's warranty.

Notice of the alleged defect must be given to the Seller, in writing with all identifying details including serial number, type of equipment and date of purchase within thirty (30) days of the discovery of the same during the warranty period.

Seller's sole obligation on this warranty shall be, at its option, to repair or replace or refund the purchase price of any product or part thereof which proves to be defective. If requested by Seller, such product or part thereof must be promptly returned to seller, freight prepaid, for inspection.

Seller warrants repaired or replaced parts of its own manufacture against defects in materials and workmanship under normal use and service for ninety (90) days or for the remainder of the warranty on the product being repaired.

This warranty shall not apply and Seller shall not be responsible or liable for:

- (a) Consequential, collateral or special losses or damages;
- (b) Equipment conditions caused by fair wear and tear, abnormal conditions of use, accident, neglect or misuse of equipment, improper storage or damage resulting during shipping;
- (c) Deviation from operating instructions, specifications or other special terms of sale;
- (d) Labor charges, loss or damage resulting from improper operation, maintenance or repairs made by person(s) other than Seller or Seller's authorized service station.

In no event shall Seller be liable for any claims whether arising from breach of contract or warranty or claims of negligence or negligent manufacture in excess of the purchase price.

THIS WARRANTY IS THE SOLE WARRANTY OF SELLERS AND ANY OTHER WARRANTIES, WHETHER EXPRESS OR IMPLIED IN LAW OR IMPLIED IN FACT, INCLUDING ANY WARRANTIES OF MERCHANTABILITY AND FITNESS FOR PARTICULAR USE ARE HEREBY SPECIFICALLY EXCLUDED.

LIABILITY LIMITATIONS: Under no circumstances shall the Seller have any liability for liquidated damages or for collateral, consequential or special damages or for loss of profits, or for actual losses or for loss of production or progress of construction, whether resulting from delays in delivery or performance, breach of warranty, negligent manufacture or otherwise.

ENVIRONMENTAL AND OSHA REQUIREMENTS: At the time of shipment of the equipment from the factory, Quincy Compressor / Ortman Fluid Power will comply with the various Federal, State and local laws and regulations concerning occupational health and safety and pollution. However, in the installation and operation of the equipment and other matters over which the seller has no control, the Seller assumes no responsibility for compliance with those laws and regulations, whether by the way of indemnity, warranty or otherwise.



an EnPro Industries company

Quincy Compressor Products: 217.222.7700
E-mail: info@quincycompressor.com
Web: www.quincycompressor.com/natural_gas.html



© 2008 Quincy Compressor, an EnPro Industries company
All Rights Reserved. Litho in U.S.A.